

OCTAVE

V70

INTRODUCTION

Congratulations and thank you for choosing the OCTAVE

V 70

You are about to enjoy the benefits of one of the world's most innovative and reliable amplifiers. Take care of it, and your amplifier will provide you with many years of listening pleasure.

You often hear people claim that there has been no real progress in tube amplifier design for years. The operating principles of tubes have been documented extensively and are well known to amplifier designers. The same can, of course, be said for transistor amplifiers.

Nevertheless, there is still room for further development with both of these technologies. This is both necessary and desirable. With tube amplifiers in particular, a general reluctance to depart from the classic circuit designs has not done the technology any favours. Today's loudspeakers and source equipment provide better performance than ever before, but also make greater demands on amplifiers. Modern sound reproduction equipment delivers a level of performance at a price that simply would not have been possible 20 or even 10 years ago.

These advances have been achieved through the application of cutting edge technology as it becomes available and affordable.

Integrating these technologies into amplifier design demands a detailed knowledge of the inner workings of amplifiers and an appreciation of the sonic ramifications of each modification.

We have specialized in tube amplification for the past 20 years, during which time we have developed a number of innovative technologies that have earned us a reputation as one of the leaders in the field.

We hope you will enjoy many hours of wonderful music with your OCTAVE amplifier.



Andreas Hofmann

CONTENTS

	Page
Introduction	3
1. Description of the V70	7
2. Safety instructions	9
2.1. Before you begin	9
2.2. Placement	10
2.3. Warranty	10
3. Setting up	11
3.1. Connecting the amplifier	11
3.2. Running in	11
4. Operation: V70 front panel	12
5. The BIAS measurement system	14
6. Connections: V70 rear panel	15
7. Tubes	
7.1. Removing the grille	16
7.2. Tube layout.....	16
7.3. Tube service life	17
7.4. Replacing tubes.....	17
8. Programmable remote control.....	18
9. Using the Black Box or Super Black Box	19
9.1. Option: External Black Box	19
9.2. Option: External Super Black Box.....	20
10. Troubleshooting.....	21
11. Technical data and dimensions.....	22
12. Specification	23
13. FAQ	24

1. DESCRIPTION OF THE V70

The V 70 is an integrated amplifier with a push-pull pentode output stage producing approx. 2 x 70 W at 2% THD.

LOAD STABILITY

Through optimization of the pentode design, we have developed a power amplifier section with exceptional load stability. This *load stability* is important because the minimum impedance of modern, high performance loudspeakers can be anywhere between 2.5 and 8 ohms. As impedances under 4 ohms are relatively common, we have optimized our output transformers for 4 ohm loudspeakers. There is no provision for 8 or 16 ohm outputs because:

1. There are practically no true 8 or 16 ohm loudspeakers being made any more.
2. A properly optimized output transformer with additional tapings would make the design very complex and would also add unnecessarily to the cost. It is not harmful to drive an 8 ohm loudspeaker from a 4 ohm output. The amplifier simply delivers slightly less power into an 8 ohm load.

ELECTRONIC STABILIZATION

The really new feature of the V 70 is the *electronic stabilization of the preamp power supply*.

Because of the high voltages involved, the technology is highly sophisticated. First used in the Jubilee monoblocs, this technology is particularly beneficial to the sound quality of smaller amplifiers. Interaction of the power amplifier with the sensitive input stages is eliminated. The sound gains more silence, without any sense of edginess - an effect normally only achieved with "giant" power supplies. Bass reproduction also gains in authority.

POWER MANAGEMENT

Preamplifier stabilization is integrated with the electronic *soft start surge control* (power management).

Soft start - ramping up of the heating and supply voltage at turn-on - is extremely important for the life and the sound performance of the tubes. It also relieves the power supply components of the strain of handling huge surge currents at turn-on.

During start-up, the *Wait* LED lights up on the front panel. When it goes out, the amplifier is ready for use. Soft start is also activated whenever there are strong fluctuations in the supply voltage, such as may occur during thunderstorms.

PROTECTION SYSTEM

Many manufacturers fail to incorporate electronic or even passive protection systems in their tube amps, which means that the life - and indeed the operational safety - of these amplifiers is greatly dependent on factors over which the user has no control.

We refuse to leave safety and service life to chance.

OCTAVE fits its power amplifiers with an *electronic protection system* as a matter of course.

1. DESCRIPTION OF THE V70

Our *protection system* incorporates an independent circuit that monitors the power output of the four power tubes. It switches the power supply off when the maximum permissible values are exceeded. The red OFF LED illuminates to show you when the protection has been activated.

This can happen for a number of reasons - for example, if the speaker outputs are short circuited or if the power amplifier is overdriven. The protection system protects the amplifier and the tubes from overload. The V 70, like all Octave amplifiers, is thus fully protected against the possibility of serious damage that often affects other valve amplifiers when overdriven.

Our system - soft start and protection circuit - rules out any possibility of 'user error'.

Owners of tube amplifiers usually receive lots of advice like: Never operate without the speakers connected; Follow the switch-on sequence exactly; Switch valve amplifiers on and off as little as possible, etc. This is certainly important advice for many amplifier brands, but is not necessary with the V 70. The built-in control system automatically takes care of this.

Another extremely useful feature is the *bias (idle current) measuring facility*.

Unlike the simpler class-A power amplifier type, AB amplifiers require adjustment of the negative grid bias to optimize idle current for the power tubes. The setting can change as the tubes age and it must also be adjusted whenever tubes are replaced. Normally, this requires test equipment and a knowledge of what and where to measure.

Setting the bias used to be a job for an electronics technician, but with the V 70, you can check and adjust the bias without any tools while the amp is on.

This adjustment has a huge influence on the sound quality and performance characteristics of an amplifier (see diagram 1 under "Specification").

All of these features make the V 70 a unique product in its class and a true, state-of-the-art design. The V70 benefits from the know-how and technologies that make our top of the range amplifiers, the Jubilee Line, reference class products.

PROTECTION SYSTEM

BIAS

2. SAFETY INSTRUCTIONS

2.1. Before you begin

Before using your V 70, please remove the protective grille and install the output tubes supplied with your amplifier in the appropriate sockets (see Removing the Grille and Tube Layout). Replace the grille before switching on.

Operating the amplifier without its protective grille is dangerous and not recommended.

In case of emergency: disconnect the plug from the mains supply

Never use an amplifier that is damaged or faulty. Make sure that it cannot be used until it has been repaired by a qualified service engineer.

Make sure that there is easy access to the IEC socket and power cord.

Do not open the case

There are dangerously high voltages and hot tubes inside this equipment. To avoid a burn or the risk of electric shock, never allow anyone except qualified personnel to open the case or remove the grille.

Servicing and maintenance

For reasons of safety, please ensure that servicing, repairs and other modifications to OCTAVE equipment are carried out only by a qualified technician. Fuses should also only be changed by a qualified technician. Always replace fuses with ones of the same type and rating. If your amplifier requires servicing, please ship or take your equipment directly to OCTAVE or to one of our authorized service centres.

Explanation of the warning symbols:



The exclamation point within an equilateral triangle is intended to alert the user to important operating and maintenance instructions.



The lightning flash with arrowhead symbol within an equilateral triangle is intended to alert the user to the presence of uninsulated 'dangerous voltages' within the product's enclosure that may be sufficient to constitute a risk of electric shock to persons.

Before connecting

Make sure that the voltage of your amplifier matches your electricity supply voltage.

Grounding

This amplifier is a protection class 1 device (with an earth conductor). To exclude the risk of electric shock in the event of a fault, the unit must be grounded. Use a three-core mains cable with a three-pin plug (supplied).

Safety warning: hot tubes!

Warning: Remove the protective grille at your own risk. OCTAVE accepts no responsibility for injuries caused by the removal of this grille.

2. SAFETY INSTRUCTIONS

2.2. Placement

1. Location

OCTAVE equipment is designed strictly for use in a dry domestic environment. Do not use it in the open air or in damp environments!

Never place plants or liquid filled containers on your OCTAVE equipment. Take care that objects do not fall or liquids are not spilled into the enclosure. Should this happen, remove the mains plug immediately and have your amplifier checked by a qualified service technician.

Condensation may form if the amplifier is taken from a cold environment into a warm one. If you do this, wait until the amplifier has reached room temperature and is dry before switching it on.

Avoid installing the unit close to sources of heat such as radiators or anywhere that it may be in direct sunlight.

Do not operate the unit near flammable materials, gases or vapours. Avoid areas where there may be heavy accumulations of dust or where the unit may be subject to mechanical vibration.

Place your OCTAVE amplifier on a stable, even surface.

2. Grille

Never operate the amplifier without the protective grille.

3. Ventilation

Make sure that your amplifier has a good flow of air around it. If you intend to install your equipment in a cupboard or a shelf unit, ensure that there is at least a ten centimetre gap between the ventilation slots and the walls all around the amplifier. The rear panel of cupboards should have ventilation holes to prevent heat build up. Do not rest the equipment on a soft surface such as carpet or foam sheeting.

2.3. Warranty

OCTAVE can only guarantee the safety, reliability and performance of this unit if modifications and repairs are carried out by specialized personnel and if the amplifier is operated in accordance with the instructions contained in this manual.

3. SETTING UP

3.1. Connecting the amplifier

1. In your own interest, please observe the Safety Precautions and positioning advice (Chapter 2)
2. Before connecting your OCTAVE amplifier up, switch off all the other equipment that you intend to connect to it. This will avoid a source of possible problems when you plug these components in.
3. Connect the cables from your signal sources such as CD player, tuner, etc. to the appropriate inputs on the amplifier. When connecting recording devices, be careful to connect the recording and replay inputs and outputs correctly.
4. Connect your loudspeakers to your V 70 amplifier, making sure that you observe the correct polarity (positive on the amplifier to positive on the speakers).



5. Check that the amplifier is switched off before connecting the power cable to the wall socket.
Before connecting the optional outboard Black Box, ensure that it is switched off. (see Chapter 9, Black Box)
6. Now switch the amplifier on using the power (on/off) switch (see Chapter 4, Operation) After switch-on, the 'Wait' LED will illuminate in addition to the normal power LED. The amplifier is ready for use as soon as this LED goes out.
7. Check that the volume control is not set at maximum before playing music through the amplifier.
8. Switch the other components on in any order.

3.2. Running in

All OCTAVE equipment is subject to a 48-hour soak test at the factory to burn in the tubes. The tubes are preselected for use in each particular model.

The sound quality of tube equipment improves throughout the initial running-in period of up to three months.

During this time, daily use is beneficial (even at high levels) but not a requirement. Continuous operation does very little to help reduce the running-in time and is therefore not recommended.

4. OPERATION - The V 70 front panel

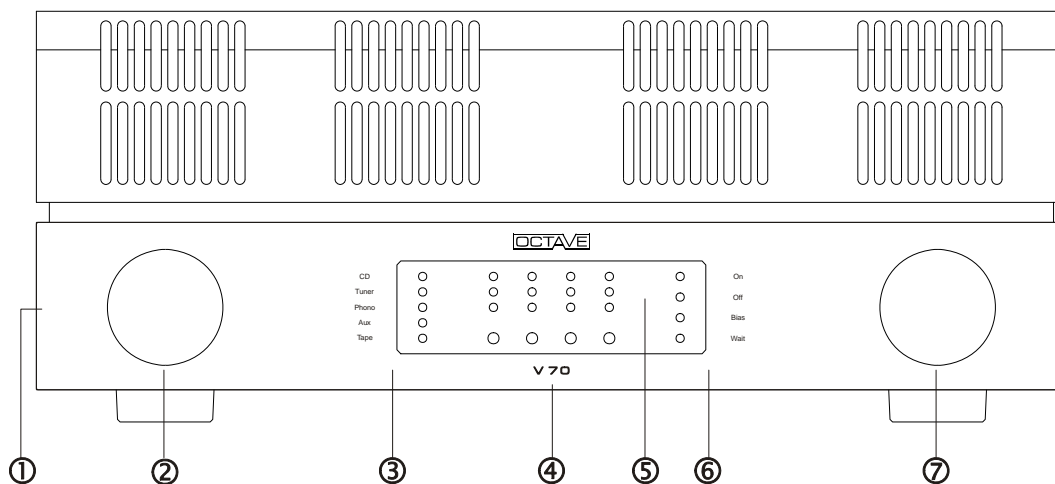

- ① **Power switch** 0 = off; 1 = on. 'ON' LED lights up
During start-up, the 'Wait' LED also lights up. (see ⑥)
- ② **Selector switch** For selecting the following inputs (clockwise):
CD, Tuner, Phono, Aux, Tape and bias adjustment (indicated by bias LED on the right hand side of the display panel)
- ③ **Input selector** The LED lights up in the display to show which source is active.
 CD Line level input for CD
 Tuner Line level input for tuner
 Phono Line level input for external phono module
 Aux Additional line level input for video, etc.
 Tape Tape playback. This type of input selector used does not permit off-tape tape monitoring. If you wish to record a CD, for example, the input must be switched to CD. Switching to the Tape input would interrupt the recording.
- ④ **Setting the bias** See chapter 5, The BIAS measurement system
- ⑤ **Remote receiver** To ensure trouble-free operation of the remote control, never obscure this area.

4. OPERATION -The V 70 front panel

- ⑥ **Status indicators**
- | | |
|------|---|
| On | (green LED) Lights up when the amplifier is on. |
| Off | (red LED) Lights up when the electronic protection system has switched the amplifier off in response to an amplifier fault. (see 'Description of the V70') |
| Bias | (yellow LED) Lights up when the bias measurement facility is switched on (see ② and Chapter 5, BIAS) |
| Wait | (yellow LED) Lights up during the soft start process immediately after switch-on. This LED goes out after about 1 minute when soft start has been completed. When there are mains supply interruptions (of the kind that occur during thunderstorms, for example), soft start cuts in automatically to restart the amplifier. |
- ⑦ **Volume control** Motorized potentiometer

5. THE BIAS MEASUREMENT SYSTEM

How to set the bias

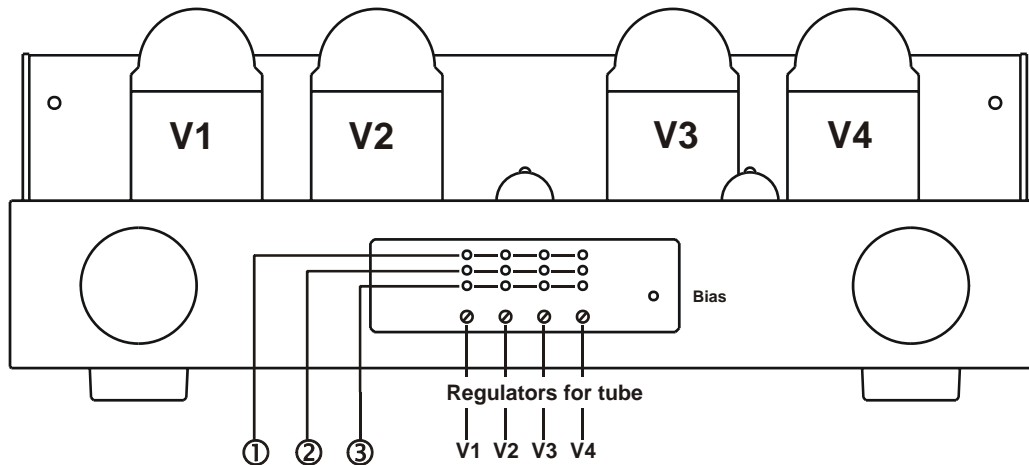

The bias measurement system

The bias measurement facility makes it easy for you to check and adjust the idle current of the output tubes. Getting the bias setting right for all four tubes is critical both for the sound of the power amplifier section and for the service life of the tubes. It guarantees consistent sound quality over the entire lifetime of the output tubes.

This is why we have built a bias measurement facility into the V 70 that allows you to carry out the adjustment yourself without the need for test equipment. Thanks to the use of precision op amps, this system allows you to set the bias to an accuracy of 0.3%, making it superior to any other adjustment method.

The use of selected output tubes only makes sense if the idle current is adjusted accurately, as is clearly shown in Fig. 1 Technical Data.

Turn the Input/Mode selector switch clockwise until the bias LED lights up showing that the measurement circuit has been activated. The 3 LEDs above each adjustment screw in the display panel indicate that the bias setting is either too low, correct, or too high. Use the screwdriver supplied to adjust the bias.

Turn the screws clockwise to increase the current. To ensure accuracy, all inputs are automatically disconnected when the measurement function is selected.

The adjusting screws are fully insulated. There is no risk of electrical shock and the adjustment procedure is completely safe.

The LED display:

①	top row:	red LEDs	Setting is too high
②	centre row:	green LEDs	Setting is OK
③	bottom row:	yellow LEDs	Setting is too low

6. CONNECTIONS: V70 rear panel

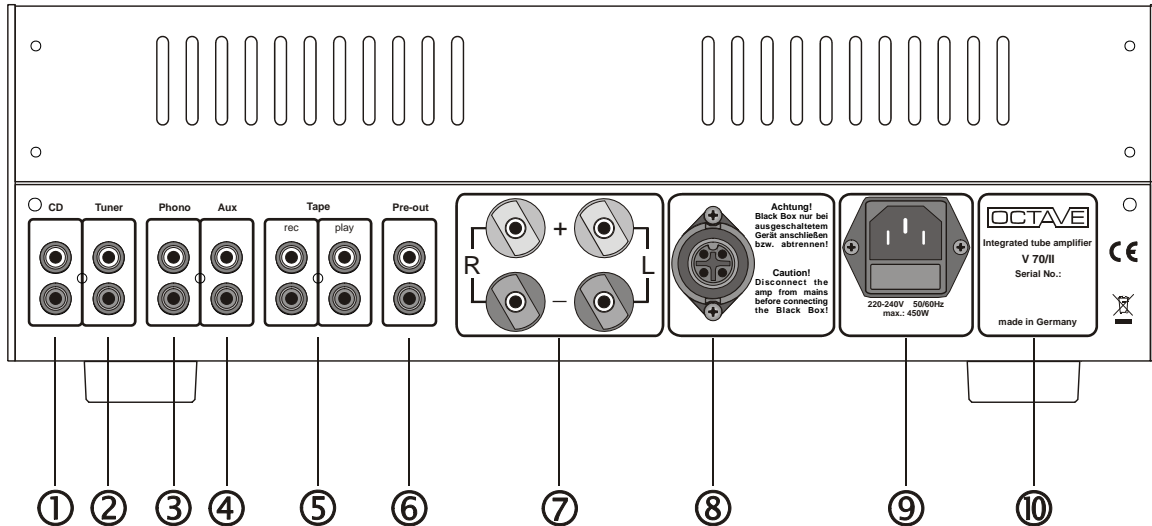

- | | | |
|---|---|--|
| ① | CD | Line level input for CD |
| ② | TUNER | Tuner line level input |
| ③ | PHONO | Line level input for external phono module |
| ④ | Aux | Additional line level input for video, etc. |
| ⑤ | TAPE REC
TAPE PLAY | Output for a tape or DAT machine
Output for a tape or DAT machine |
| ⑥ | Pre-out | Regulated preamp output for active subwoofer and so on |
| ⑦ | Loudspeaker outputs | Speaker connection terminals |
| ⑧ | Black Box connection | The Black box is an outboard power supply upgrade for the power amplifier (see chapter 9. Black Box)
The V 70 must be switched off using the power switch before connecting and disconnecting the Black Box. |
| |  | |
| ⑨ | Power connection | Mains AC receptacle, IEC socket combined with mains fuse holder. The rating of the fuse is depending on your local mains voltage. |
| ⑩ | Model identification plate | Model and serial number. |

7. TUBES

7.1. REMOVING THE GRILLE

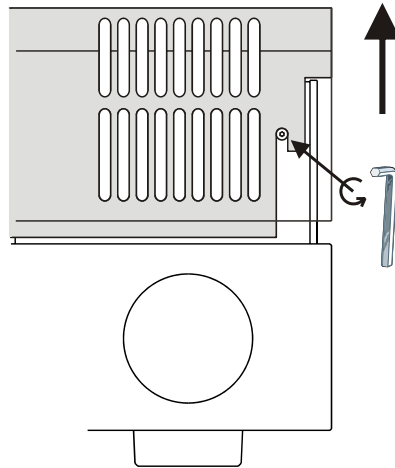

To remove the grille:

1. For your own safety, switch the amplifier off using the on/off switch.
2. Release the two M4 socket head bolts on the right and left of the grille. (Scope of delivery includes an allen wrench)
3. Pull the grille upward to remove. (The nuts that these bolts screw into are the captive type. They will not fall into the casing when fully unscrewed.)

7.2. TUBE LAYOUT

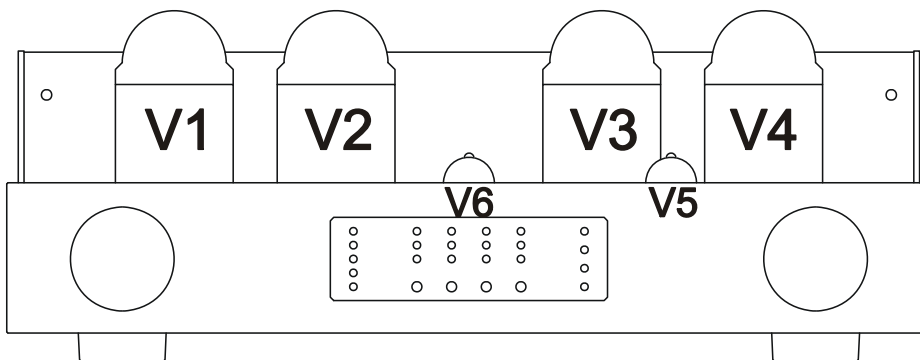

Output tubes:	V1 - V4:	6550 fitted as standard
	V1 + V2	Possible alternatives are KT88, 6L6, and KT66
	V3 + V4	left channel
		right channel
Driver tubes:	V5	ECC83 (E83CC) = input tubes
	V6	ECC88 (E88CC, 6922) = driver tubes
		both channels use the V5 and V6 output driver tubes

7. TUBES

7.3. TUBE SERVICE LIFE

- Thanks to the protection circuits and soft start electronics, the output tubes used in your amplifier should achieve an average service life of 5 years.
- The driver tubes can last for 10 years or more.
- Because the tubes have different service lives, you will never have to renew the entire tube complement at the same time.
- Please note that some tubes need a long time (up to 300 hours) to achieve their optimum sound quality.

7.4. Replacing tubes

- **Driver tubes**

Replacement driver tubes require no adjustment.

- **Output tubes:**

General procedure:

1. Switch the amplifier off and allow it to cool down for 10 minutes. Remove the old tubes and fit the new ones.

2.  Before you switch the amplifier back on, turn all bias adjustment controls counterclockwise (this reduces the anode current substantially). You will hear a click when the controls reach the minimum setting. These controls are three-turn potentiometers, i.e. it takes three revolutions to go from the maximum to the minimum setting.

3. Switch the amplifier on. After the 'Wait' period, all 4 minus-LEDs should illuminate yellow. If at this stage any of the LEDs are green or red, this indicates a faulty tube that must be replaced.

- 3.1. New, untested output tubes should be burned in with a low anode current. To do this, leave the amplifier on for 2 hours. Then adjust all the tubes.

- 3.2.  Original Octave tubes
There is no need to burn in original Octave replacement tubes. After replacement, leave the power on for 10 minutes to allow the amplifier to warm up. Then, adjust the bias.

8. PROGRAMMABLE REMOTE CONTROL

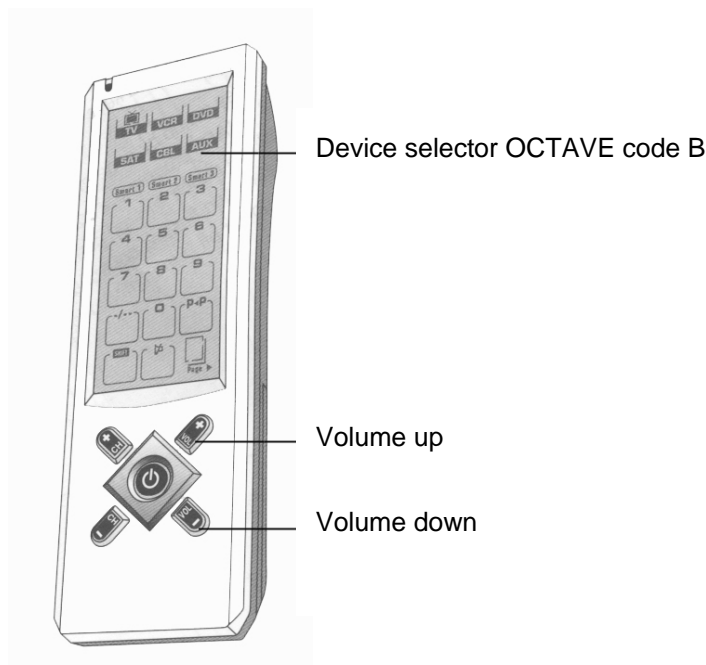

Select your OCTAVE amplifier on the touch screen panel with button AUX. Once selected you can always control the volume directly by pushing the button Vol + or Vol - .

Detailed information relating the use of the remote control you find in the owner's manual of the HOME THEATRE MASTER REMOTE

9. USING THE (SUPER) BLACK BOX

Description

OCTAVE, with the Black Box technology, offers an instrument to optimizing the OCTAVE amplifier in respect to the speaker. This flexibility is a unique feature of the OCTAVE brand.

The dynamic and tonal stability of an amplifier is strongly dependent upon the stability and capacity of the power supply, therefore the Black Box and Super Black Box were developed as external upgrades to the OCTAVE amplifiers' power supply storage capacitors by increasing their capacitance by a factor of 4 (Black Box) or 10 (Super Black Box), respectively. This is a tremendous benefit if the speaker is difficult to drive. Loudspeaker efficiency is made less critical, while the amplifier is enabled to handle speakers with minimum impedances as low as 2 Ohms.

The power supply capacitance increase realized via use of the Black Box or Super Black Box stabilizes current delivery and reduces the impedance interaction of the load. This improves dynamic range, separation, depth, soundstage size and articulation, rendering the musical reproduction clearer throughout the entire frequency range. The amplifier remains unaffected by mains variations and interferences due to the noise filtering characteristics of the capacitors

9. USING THE (SUPER) BLACK BOX

9.1. Option: External Black Box

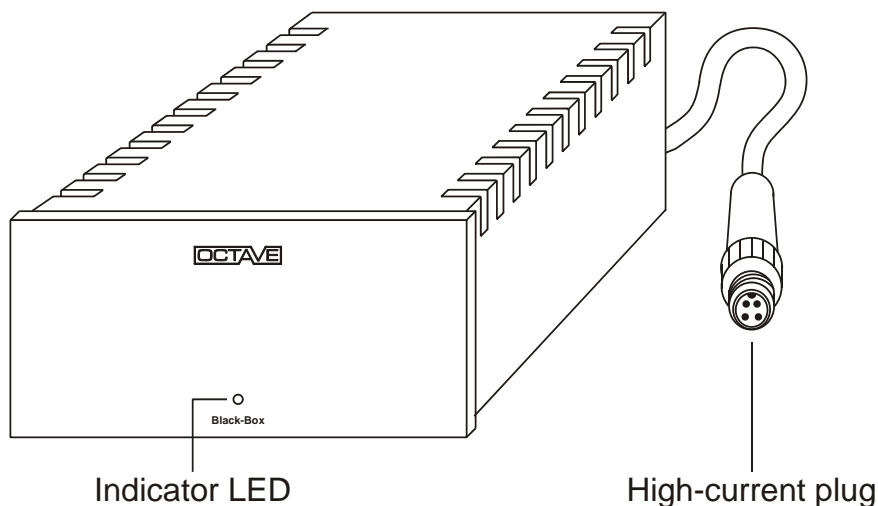

The LED lights up continuously when the power amplifier is on. The LED goes out when the protection circuitry trips. This is normal, as the protection circuitry cuts the power to the amplifier.

Specifications:

Dimensions: Width x height x depth = 170 x 97 x 257mm
Weight: 3.1kg
Connection cable: 70cm long. Longer lengths available upon request

Connecting to the amplifier



- **Warning!!** Before connecting the Black Box, switch the unit off using the power switch and wait for 1 minute.
When inserting the connector, guide the anti-rotation lug carefully into the mating recess in the socket.
- When you switch the amplifier on, the LED on the front panel of the Black Box will illuminate.
Please note:
When the amplifier's electronic protection circuitry cuts in, this will cause the LED on the Black Box to go out, as it interrupts the power to the amplifier.
- Should you wish to disconnect the Black Box, switch the amplifier off first and wait until the LED on the Black Box goes out before doing so.

9. USING THE (SUPER) BLACK BOX

9.2. Option: External Super Black Box

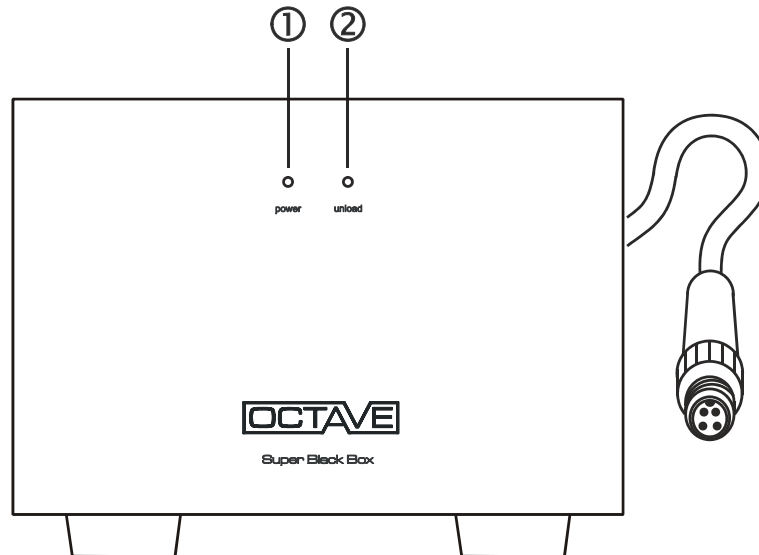

- ① **Blue Power LED:**
The blue Power-on LED illuminates when the power amplifier (or integrated amplifier) is switched on via the amplifier's power on/off switch.
- ② **Yellow Discharge LED:**
When the power amplifier is switched off, the yellow Unload LED illuminates for about 2 seconds. This indicates that the rapid discharge circuit is discharging the electrolytics in the SBB. The discharge circuit also activates if the SBB connecting cable is removed accidentally. This makes it impossible for an SBB to contain a dangerous charge while it is disconnected.

Dimensions and weight

Dimensions: (Width x height x depth) = 203 x 159 x 320mm
 Weight: Approx. 7.5kg
 Connection cable: 80cm long. Longer lengths available upon request

Connecting to the amplifier

see Black Box

10. TROUBLESHOOTING

■ Hum and crackling

Hum in an audio system is often caused by several system components being earthed individually. It is particularly common with tuners, VCRs or satellite receivers where the earthed aerial cables can cause a hum loop via the aerial input.

Tube power amplifiers are normally earthed, and the V 70 is no exception. However, removing the earth wire on your mains plugs is not a solution, You can isolate the aerial earth connection with a special signal isolator. This device has no adverse affect on the sound or picture quality of tuners or TVs.

Check also that the phono plugs are a tight fit. Bend the outer earth contact inwards slightly if necessary. Sometimes the internal pin in a phono plug may not be a tight enough fit, in which case you should change either the interconnect cable or the socket.

■ Switching interference

Older fridges and 12 V halogen lamps can cause cracking through the loudspeakers when they switch on and off.

Solution: The only solution is to use a single power socket board for your entire system and to use a different power outlet in your listening room. However, it is not always possible to eliminate the problem entirely.

■ Channels are not balanced

1. Damaged cables and poorly fitting phono plugs can create resistance in the signal path enough to reduce the output level of one channel.

Solution: Try new cables or clean the plugs and sockets with isopropyl alcohol.

2. A tape or DAT machine connected to the REC Out may have a faulty Record input (or faulty interconnect cable) causing the signal to overload. This can result in an imbalance between the left and right channels.

Solution: Disconnect the tape/DAT machine

3. A faulty output tube can cause a drop in output in one channel and generate distortion at higher output levels.

Solution: Locate the defective tube using the bias adjustment facility. Replace the tube.

■ Increased hiss on one channel

An irregular hissing sound is a sign of a worn *driver tube*.

Solution: Replace the worn tube.

11. TECHNICAL DATA AND DIMENSIONS

In- and Outputs:

Inputs: 5 x RCA, including one optional Home Theatre Bypass input
 Outputs: 1 x RCA Record output, 1 x regulated Preamplifier output, 1 x Loudspeaker output

Amplifier

Power output: 2 x 70 W / 4 ohms
 Frequency response: 10 Hz - 80 kHz / ± 0.5 dB
 Total harmonic distortion: $< 0.1\%$ at 10 W into 4 ohms
 Signal-to-noise ratio: > 100 dB
 Minimum load impedance: 2 ohms
 Input sensitivity: 120 mV, normal gain
 700 mV, low gain

General

Power consumption: 130 W minimum, 320 W at full power
 Weight: 21.6 kg
 Standard accessories: power cable,
 3mm slotted screwdriver for BIAS measurement,
 Allen wrench 2 mm for removing the grille,
 IR remote control
 Dimensions: Overall dimensions in mm

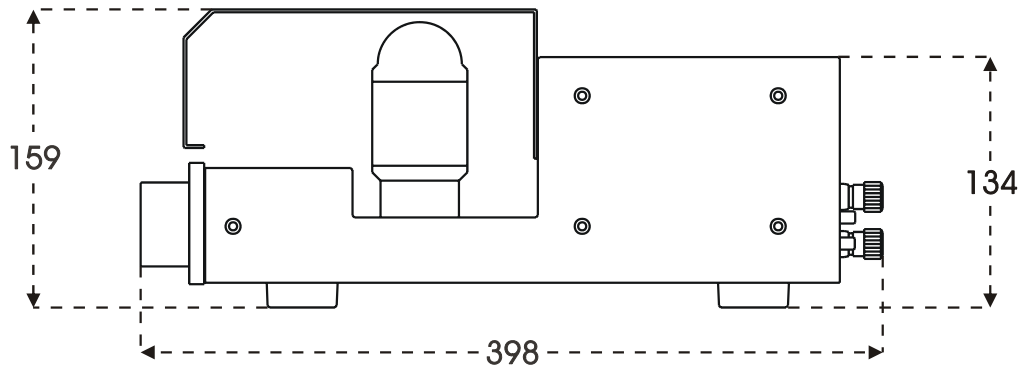
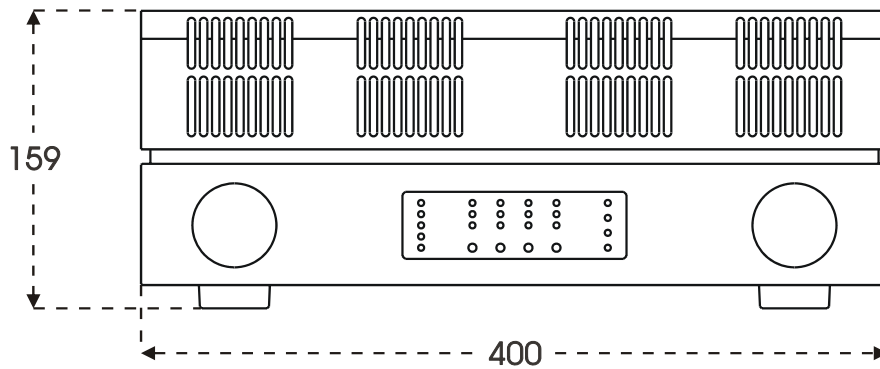

12. SPECIFICATION

Features

- Remote control as standard
- Input selector via gold plated relays
- Gold plated phono sockets
- Double sided PCBs with plated through holes
- Ceramic tube bases with silver contacts
- Specially selected longlife, burned-in tubes
- Professional, low inductance reservoir electrolytics, LH grade
- Modular aluminium case
- Available in a range of anodized colours

Distortion at 4V into 6 ohms between 30 Hz and 20 kHz at a variety of bias settings

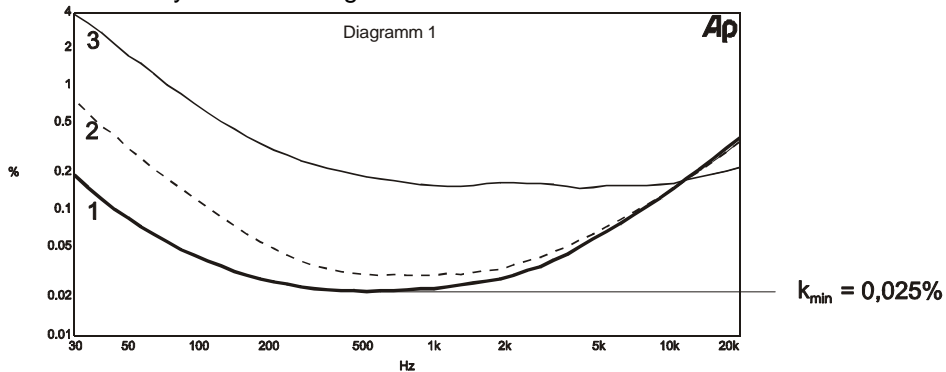

- Curve 1: Bias adjusted correctly
- Curve 2: Bias 10% out
- Curve 3: Bias 30% out

Frequency response right and left channel, 4 V into 4 ohms

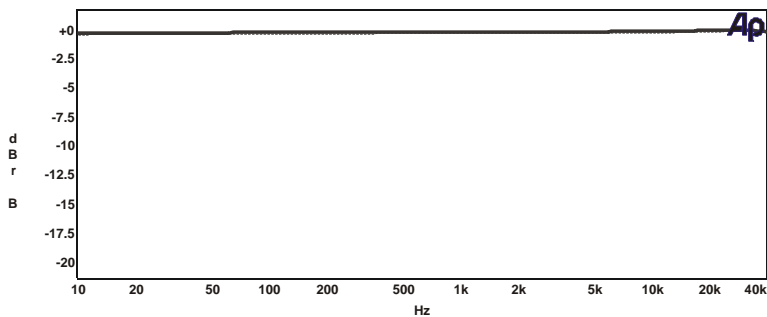

The frequency response for both the left and right channels measures within extremely tight 0.2 dB limits from 10 to 40 kHz \pm .

13. FREQUENTLY ASKED QUESTIONS (FAQ)

1. Can you operate the V70 when no loudspeakers are connected?

Yes. The V 70, like all OCTAVE amplifiers, is fully protected against open circuit operation, i.e. the amplifier will come to no harm if it is operated without loudspeakers connected.

2. How do you recognize a faulty tube?

There are 3 different symptoms indicating a faulty tube:

1. Broken heater filament. The tube stops glowing
2. Defective cathode layer. The tube glows, but no current can flow. You can confirm this fault using the bias display panel - no amount of adjustment will be able to extinguish the minus LED.
3. Internal short circuit. Normally, the electronic protection cuts in and the red Off LED illuminates, or the tube will not respond to bias adjustment (the display keeps returning to the red area).

With faults 1 and 2, the amplifier will still operate, although the channel containing the faulty tube will be quieter than normal. At low listening levels, the fault may not be obvious, but distortion will become evident at higher listening levels.

If fault 3 occurs, the protection circuits will normally switch the amplifier off. You may also hear loud background noises just before it switches off, although these are not harmful to the amplifier.

3. Is there a loss of sound quality as tubes age?

No. Tubes normally sound the same throughout their service life and our soft-start technology contributes greatly to extending the service life of tubes. You can tell when an output tube has reached the end of its useful life: it becomes impossible to adjust it correctly. Driver tubes cannot be checked, but these will generally last for well over 10 years.

4. Does the V 70 have to have all tubes fitted?

In principle, the V 70 will also operate without tubes. It is sometimes useful to do this when testing the operation of the switching functions such as the selector switch, remote control, etc. Of course, it is not possible to play music under these circumstances.

For test purposes, a channel may also be used with a single output tube, although its power output will, of course, be reduced. The amplifier will come to no harm if it is operated continuously like this.

Operation without driver tubes is also possible for test purposes, although, for obvious reasons, music playback is not possible.

5. What is the significance of loudspeaker impedance and efficiency?

The impedance and efficiency of modern loudspeakers is not an issue for OCTAVE amplifiers. The often-quoted damping factor is not normally a guarantee that an amplifier will exert tight control over the loudspeakers. In practice, speakers with a sensitivity of 85 dB and higher are suitable for use with tube amplifiers. The high stability of the OCTAVE power amplifier technology even allows you to connect speakers that dip as low as 2 ohms.

13. FREQUENTLY ASKED QUESTIONS (FAQ)

6. What is the idea of selectable gain?

It becomes difficult to adjust the volume when driving loudspeakers with sensitivities greater than 98 dB. As the range of adjustment is limited to the lower end of the volume control, it is difficult to adjust the volume with any precision. The gain switch is provided to deal with this problem. It reduces gain by a factor of 4, making volume adjustment easier and reducing background noise at the same time.

7. What cables are suitable for tube power amplifiers?

The cable manufacturers are now offering cables that have supposedly been designed specifically for tube amplifiers. Although such cables may be of good quality, there is no need to use special cables with tube amplifiers. Speaker cable can exhibit high values of capacitance and inductance, and tube amplifiers are better able to deal with these characteristics than transistor amplifiers. The only exception would be in the case of a tube preamp to power amp interconnect cable longer than 5 metres. In this instance, a low capacitance cable is advisable.

8. Why are balanced inputs rarely seen on integrated tube amplifiers?

Unlike transistor amplifiers, it is not possible to design balanced (or bridgeable) tube power amplifiers. You may come across an occasional "quasi-balanced" tube power amp, but this makes little sense when you think about it, because it is complex, and tube tolerances make it difficult to implement. This is why unbalanced remains the better approach for tube equipment. It also has the added benefit of superior long-term stability.



We reserve the right to alter and improve the specifications in pursuit of better. OCTAVE logo is a registered trade mark of Andreas Hofmann. Copyright by Andreas Hofmann. Reproduction in whole or part is prohibited.
edited EN2010

OCTAVE AUDIO
Germany
www.octave.de