

OCTAVE

JUBILEE CLASS A

Owner's Manual

English

## INTRODUCTION

**Congratulations and thank you for choosing OCTAVE's Single Ended Mono Power Amplifiers**

### JUBILEE Class A

With the JUBILEE Class A you have purchased the latest and most advanced development from our company.

You often hear people claim that tube amplifier design has not progressed for years. The operating principles of tubes have indeed been documented extensively and are well known to amplifier designers. Of course, the same can be said for transistor amplifiers.

However, advances in both technologies are still possible thanks to the development of innovative and improved components, our greater appreciation of the fundamental principles and, of course, deeper and more advanced insights into the interaction of amplifier and loudspeaker. With tube amplifiers in particular, a general reluctance to depart from the classic circuit designs has not done the technology any favors. Although today's loudspeakers and source equipment provide better performance than ever before, they also present greater demands on amplifiers. Modern sound reproduction equipment delivers a level of performance at a price that simply would not have been possible 20 or even 10 years ago.

These advances have been achieved through the application of the latest technological developments as they become available and affordable. OCTAVE has specialized in tube amplification for more than 30 years, during which time we have developed a number of innovative technologies that have earned us a reputation as one of the leaders in the field.

Here's wishing you many happy hours of musical pleasure!



Andreas Hofmann



## CONTENTS

	Page
Introduction .....	3
1. Description of the JUBILEE Class A .....	6
<b>2. Safety instructions</b> .....	7
2.1. Before you begin .....	7
2.2. Placement .....	8
2.3. Warranty .....	8
<b>3. Getting started</b> .....	9
3.1. Package contents .....	9
3.2. Unpacking .....	9
3.3. Removing the grille .....	10
3.4. Installing the power tubes .....	11
3.5. Switching on for the first time: functional test, the soft-start feature .....	12
3.6. Connecting the unit .....	12
<b>4. The operation</b> .....	13
4.1. Touchscreen Display JUBILEE Class A .....	13
4.2. Rear panel JUBILEE Class A .....	16
4.2.1. Rear panel JUBILEE Class A without remote .....	16
4.2.2. Rear panel JUBILEE Class A with remote activation .....	17
<b>5. Advanced functions</b> .....	18
5.1. Soft-Start, Inrush current limitation .....	18
5.2. Ecomode (power saving mode) .....	18
5.3. Muting function .....	18
5.4. Operating mode Class A, Class A/B .....	19
5.5. BIAS control .....	20
5.6. Electronic Protection System .....	21
<b>6. Tubes</b> .....	23
6.1. Removing the grille (see chapter 3.2.) .....	23
6.2. Tube layout .....	23
6.2.1. Tube layout output tubes .....	23
6.2.2. Tube layout driver tubes .....	24
6.3. Replacing the tubes .....	25
6.4. Running in the tubes .....	25
6.5. Tube service life .....	25
<b>7. Troubleshooting</b> .....	26
<b>8. Frequently Asked Questions (FAQ)</b> .....	27
<b>9. Technical data</b> .....	28

## 1. DESCRIPTION OF THE JUBILEE Class A

At the High End trade fair in Munich, Octave proudly introduces a new milestone in the world of high-end power amplifiers: the Jubilee Class A, a reference monaural power amplifier that bridges the gap between traditional push-pull designs and the single-ended Class A concept.

For decades, Octave has celebrated the extraordinary musicality of the tube for its unrivalled ability to convey the emotion and soul of music – with depth, nuance, and natural warmth that a transistor can rarely approach – while acknowledging they also have clear limitations: lower output power, higher distortion, and stability issues. Octave's innovation lies in the seamless combination of tube technology and state-of-the-art semiconductor technology to overcome the disadvantages of classic tube circuits, thereby unleashing their full musical expression and potential.

Octave's push-pull amplifier designs have long been valued for their unique combination of power and control without losing the distinctive character that make tubes special. For listeners who prefer a softer, more romantic sound, founder and chief engineer, Andreas Hofmann, embarked on a series of single-ended Class A concept amplifiers, beginning with the V16 Single-Ended Class A – a single-ended triode headphone and loudspeaker amplifier with exceptionally low distortion and unusually high output power (8W) for such a design.

Following the V16, the Jubilee 300B mono power amplifier was introduced. Among other innovations, the Jubilee 300B employs a unique, dedicated AC filament heater circuit whose massive transformer provides silent, steady power to a trio of 300B tubes at 7Hz. This eliminates any sign of power line hum to reveal the full potential of the venerable 300B. Next, the V70 Class A brought the Octave single-ended concept to a higher-power integrated amplifier; and now, the Jubilee Class A follows, positioned between the powerful MRE220 SE push-pull monos and the mighty, finely-tuned Jubilee Mono Ultimate amplifiers.

Is the new Jubilee Class A better?

At Octave, we don't necessarily believe in "better." What we do believe in, however, is a strong vision – and when that vision translates into sound, true miracles can happen. The Jubilee Class A is not an optimized version of any predecessor, rather the realization of a new approach born of the unique vision and technical expertise of Andreas Hofmann. From the circuitry to the mechanical construction, everything was designed by Andreas and executed by his dedicated team at Octave, with the vast majority of parts made in-house, or sourced from within an hour of the factory in Karlsbad, Germany. The inaugural pair of Jubilee Class A was manufactured by the Octave team with the same dedication and commitment to quality for which Octave amplifiers are valued worldwide.

Sonically, the Jubilee Class A was not designed to surpass the Jubilee Mono Ultimate as such, but rather to play a crucial role in the Octave portfolio: a power amplifier that combines the musicality and smoothness of Class A with the endurance and control of push-pull technology. The result is an amplifier in which musicality, finesse, and power come together in perfect balance. For the appropriate loudspeakers – where bandwidth and dynamics go hand in hand with timbral richness and refinement – the Jubilee Class A is the ideal partner.

The Jubilee Class A is more than a new product – it represents a new chapter in amplifier development.

**A balance of power and refinement, control and emotion, precision and soul.**

## 2. SAFETY INSTRUCTIONS

### 2.1. Before you begin

**In case of emergency: disconnect the plug from the mains supply**

Never use an amplifier that is damaged or faulty. Make sure it has been labeled as defective and that it cannot be used until it has been repaired by a qualified service engineer. Make sure that there is easy access to the IEC socket and power cable.



**Do not open the case**

There are dangerously high voltages and hot tubes inside this equipment. To avoid a burn or the risk of electric shock, never allow anyone except qualified personnel to open the case or remove the grill.

**Service and maintenance**

For reasons of safety, please ensure that servicing, repairs and other modifications to OCTAVE equipment are carried out only by a qualified technician. Defective fuses should also only be replaced by a qualified technician. Always replace fuses with ones of the same type and rating. If your amplifier requires servicing, please ship or take your equipment directly to OCTAVE or to one of our authorized service centers.

**Symbols and terms used in this instructions**

	<p>Caution! Text passages marked with this symbol contain important information which must be observed if the amplifier is to operate safely and without problems.</p>
	<p>This information symbol marks text passages which provide supplementary notes and background information; they are intended to help the user understand how to get the best out of the amplifier</p>

**Before connecting**

Make sure that the voltage of your amplifier matches your local mains voltage.

**Grounding**

This amplifier is a protection class 1 device, with an earth conductor. Therefore a three-pin power cable with a protective earth contact must be used (included in the scope of delivery).

## 2. SAFETY INSTRUCTIONS

### 2.2. Placement

#### Location

- OCTAVE equipment is designed strictly for use in a dry domestic environment. Do not use it in open air or in damp environments!
- Never place plants or liquid-filled containers on your amplifier. Take care that objects do not fall or liquids are not spilled into the enclosure. Should this happen, disconnect the mains plug immediately and have your amplifier checked by a qualified service technician.
- Condensation may form if the amplifier is taken from a cold environment into a warm one. In this case, wait until the amplifier has reached room temperature and is dry before switching it on.
- Avoid installing the amplifier close to sources of heat, such as heaters, or anywhere that it may be in direct sunlight.
- Do not operate your OCTAVE amplifier near flammable materials, gases, or vapors. Avoid areas where there may be heavy accumulations of dust or where the amplifier may be subject to mechanical vibration.
- Place your OCTAVE amplifier on a stable, even surface.

#### Cover

Never operate the amplifier without the cover.

#### Ventilation

- Ensure sufficient air circulation around your amplifier. If you intend to install your equipment in a cupboard or a shelf unit, ensure that there is at least a 15 centimeter gap between the ventilation slots and the walls all around the amplifier.
- To prevent heat accumulation, the back of the cupboard should have ventilation holes.
- Do not rest the equipment on a soft surface such as carpet or foam sheeting.

### 2.3. Warranty

OCTAVE can only guarantee the safety, reliability and performance of this unit if modifications and repairs are carried out by specialized personnel and if the amplifier is operated in accordance with the instructions contained in this manual.

Octave Audio offers a 3-year manufacturer's warranty on the unit and a 6-month warranty on the tubes we use. This warranty covers only defects and manufacturing flaws. Damage resulting from misuse or improper handling is not covered by this warranty. All warranty claims must be supported by a copy of the original invoice. Warranties are valid only in the country or sales territory of the original origin or distribution. Should warranty service be required, it must be handled through an authorized Octave dealer/distributor in the country where the product was purchased by the end customer.

### 3. GETTING STARTED

#### 3.1. Package contents

##### Scope of delivery

- 2 x tube mono power amplifier JUBILEE Class A.
- 2 x set of 6 pc power tubes (standard tubes: 6 x KT120)
- Power cord: 3-pin C19 IEC power cord (not for all countries available)
- Allen key size 2, to remove the cover and the transportation handles.
- Octave cleaning cloth and soft gloves.
- Owner's manual with certificate.

#### 3.2. Unpacking

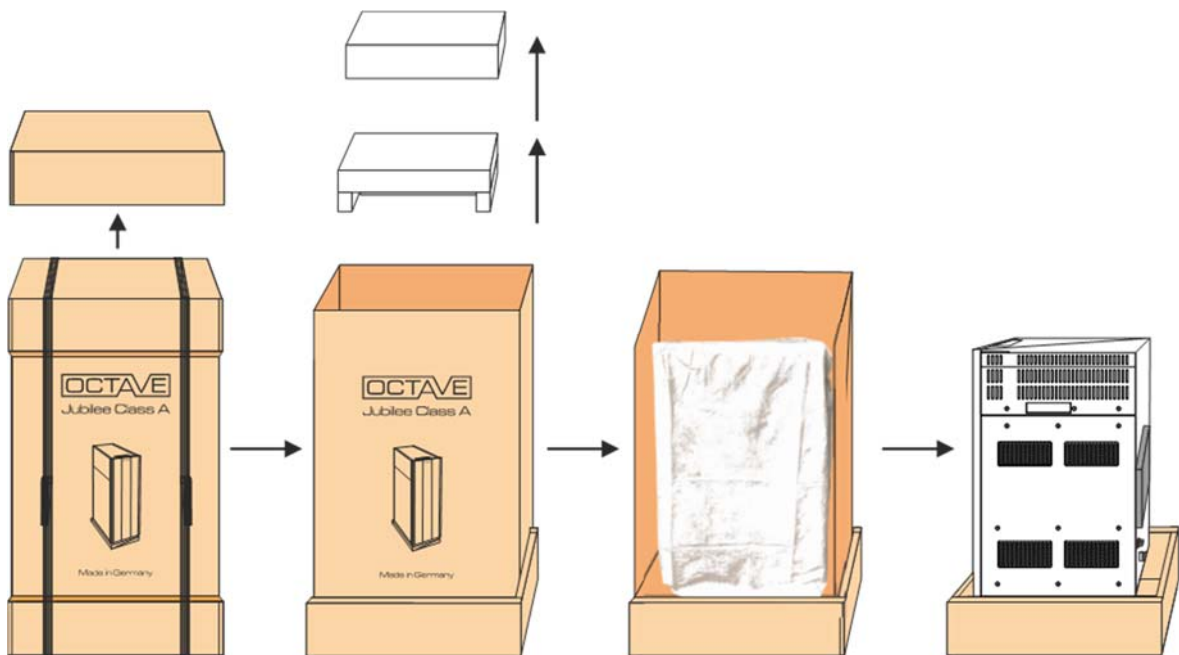

Now you can lift the Jubilee Class A out of the packaging using the cutouts on the left and right of the lid and place it in the desired location.

## 3. GETTING STARTED

### 3.3. Removing the grille

Operation of the device without protective grid is not permitted and is at your own risk!

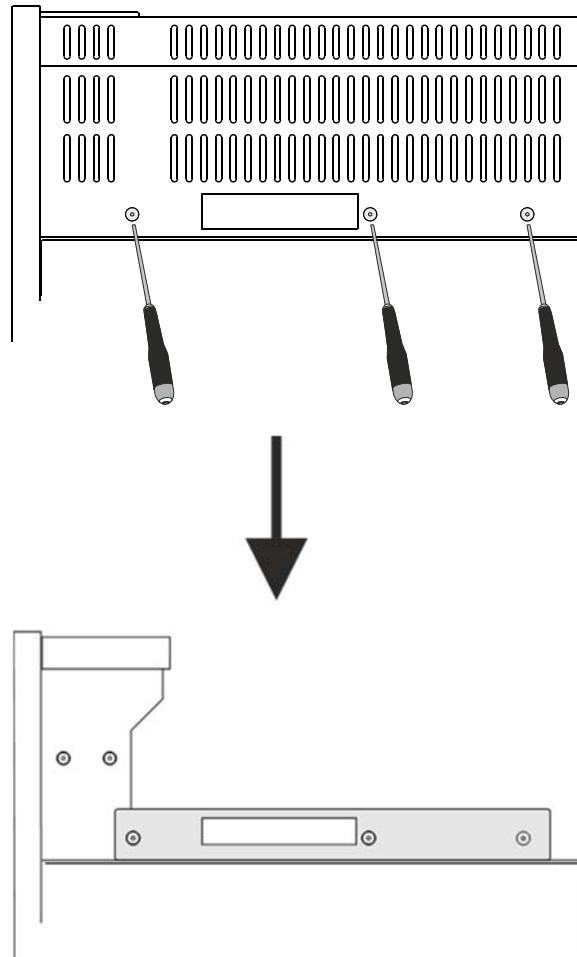

#### Procedure

- ① For your own safety, make sure that the amplifier is not connected to mains.
- ② Completely remove the six hexagonal screws using the Allan key supplied. There are three screws on each side.
- ③ Carefully pull the grille upward to remove.  
The dashed line indicated bracket can remain as a carrying aid.  
The device can be worn on the brackets with gloves.
- ④ The brackets can be removed with the two screws visible inside (same size as above).  
Then retighten these screws again.  
When you reinstall the grille, the brackets must also be reinstalled.

### 3. GETTING STARTED

#### 3.4. Installing the power tubes

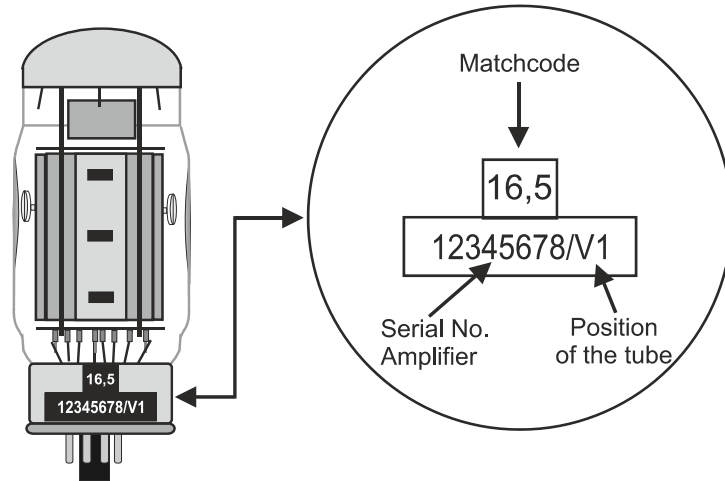

The output tubes included with your JUBILEE CLASS A are strictly selected by us and have a corresponding match code. (See chap 6 "Tubes")

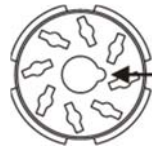

The anti-rotation recess on the tube sockets prevents incorrect insertion of the tubes.

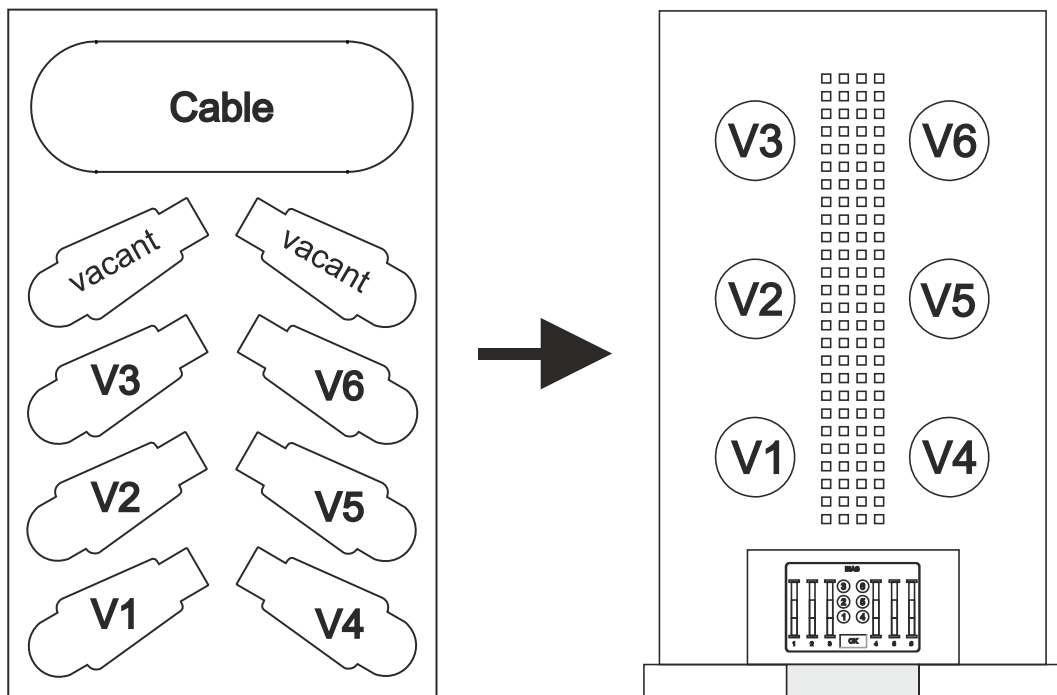

### 3. GETTING STARTED

#### 3.4. Switching on for the first time – functional test, the Soft-Start feature

The JUBILEE Class A is equipped with a multi-stage Soft-Start-Turn-On protection circuit which extends component as well as tube life considerably by protecting against stress caused by typical high inrush currents during switch on.

##### Procedure

- ① Check if the mains switch is in position 0. You will find the mains switch on the left side of the power amps.
- ② Connect your amplifier to the mains using the supplied power cable.
- ③ Now switch on the JUBILEE CLASS A using the power switch.  
The welcome screen of the touchscreen display will light up. "Please Wait" will appear. "Warm Up" will flash until the device is ready for use. The soft start takes 70 seconds.



- ④ When the device is ready for use, the menu gear icon will appear on the display.  
You can now tap the menu gear icon with your finger and then adjust the individual menu items. See chap. 4. Operation

#### 3.5. Connecting other components to the JUBILEE Class A



##### Procedure

- ① Be sure to switch off the JUBILEE Class A again!
- ② Connect the other components of your system to the appropriate sockets on the rear of the JUBILEE Class A (see chapter 4.2. Rear panel).
- ③ Make sure that the switch settings of the display and the rear panel (RCA or XLR) correspond to the desired settings. (See chap. 4.1 Display and 4.2 Rear panel)
- ④ Switch on the JUBILEE Class A using the mains power switch and wait a few minutes. Now you can play music.

## 4. THE OPERATION

### 4.1. Touchscreen Display JUBILEE CLASS A

Turn on the JUBILEE CLASS A using the power switch.  
The touchscreen display will light up.

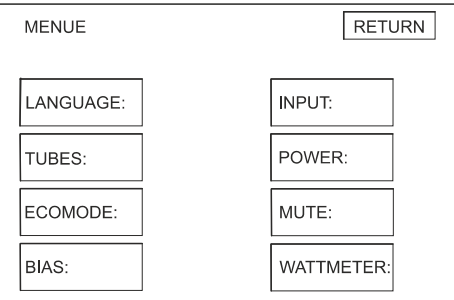
	<p><b>Startup Phase: Soft Start</b></p> <p>The device starts up gently. The display shows "Start" and "Please Wait".</p>
	<p><b>Warm-up phase: Soft start</b></p> <p>After a few seconds, the startup phase (initialization) is complete and the warm-up phase begins. The "Warm Up" indicator flashes until the device is ready for use. The soft start phase, the gentle startup of the device, lasts a total of 70 seconds.</p> <p>See chap. 5.1 for more information on soft start.</p>
	<p><b>The device is ready.</b></p> <p>When the device is ready, the menu gear icon will appear on the display.</p> <p>You can now tap the menu gear icon with your finger.</p>
	<p>All important functions of the power amplifier can be adjusted to your needs via the menu.</p> <p>Once you have selected an individual menu item, the selection remains until you want to change it again.</p>

## 4. THE OPERATION

### 4.1. Touchscreen Display JUBILEE CLASS A

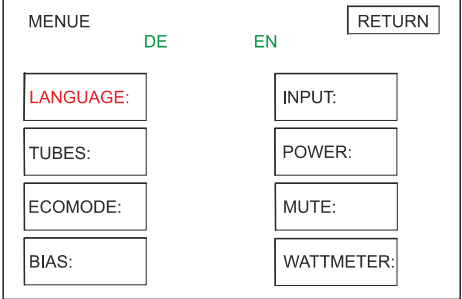
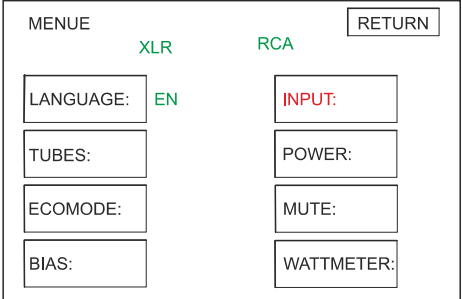
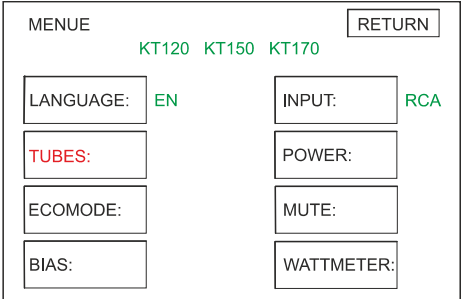
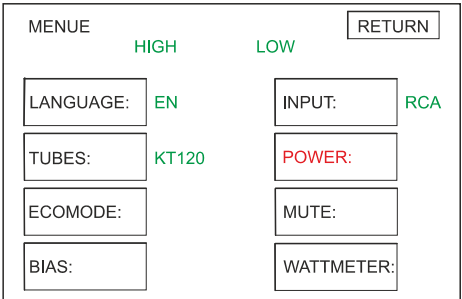
	<p><b>LANGUAGE</b></p> <p>Under the "Language" menu item, you can choose between German and English</p> <p style="text-align: center;"><b>DE and EN</b></p> <p>After making your selection, the chosen language will appear in green next to the selection button.</p>
	<p><b>INPUT</b></p> <p>For input selection, unbalanced RCA inputs and balanced XLR inputs are available:</p> <p style="text-align: center;"><b>RCA and XLR</b></p> <p>You decide which connection you prefer.</p> <p>See chap. 4.2. Rear panel</p>
	<p><b>TUBES</b></p> <p>In the "Tubes" menu you can select the tubes:</p> <p style="text-align: center;"><b>KT120 KT150 KT170</b></p> <p>Only these three types of tubes may be used. The standard tubes are the KT120.</p> <p>See chapter 6. Tubes.</p>
	<p><b>POWER</b></p> <p>In the Power menu, you select in which mode you want to operate the JUBILEE CLASS A. You can choose between</p> <p style="text-align: center;"><b>HIGH and LOW</b></p> <p>where Power LOW delivers up to 160 W in Class A mode and Power HIGH delivers up to 280 W in A/AB mode..</p> <p>See chap.5.4. Operating mode Class A, Class A/B</p>

## 4. THE OPERATION

### 4.1. Touchscreen Display JUBILEE CLASS A

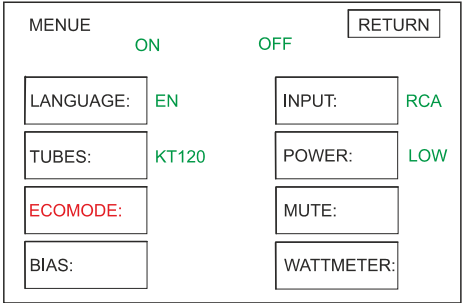
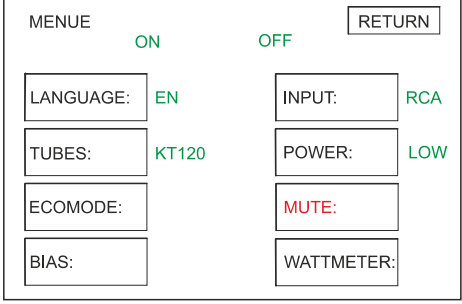
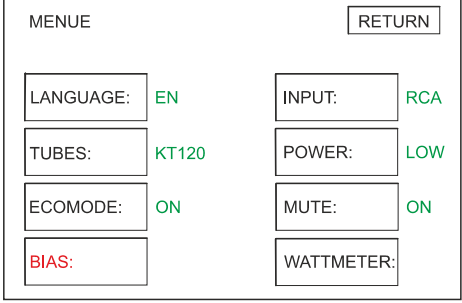
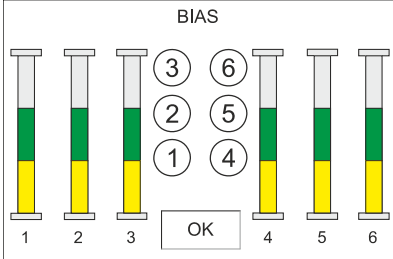
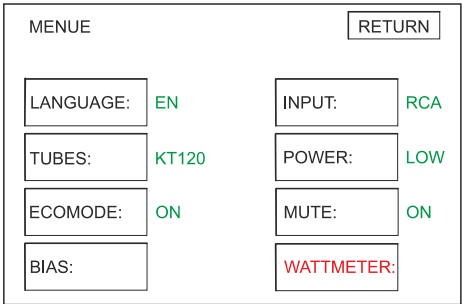
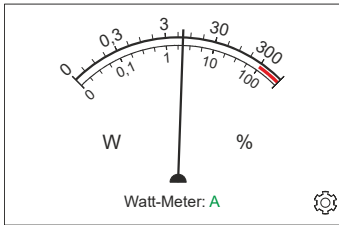
 <p>MENUE <span style="margin-left: 100px;">ON</span> <span style="margin-left: 100px;">OFF</span> <span style="float: right;">RETURN</span></p> <p>LANGUAGE: EN      INPUT: RCA</p> <p>TUBES: KT120      POWER: LOW</p> <p><b>ECOMODE:</b>      MUTE:</p> <p>BIAS:      WATTMETER:</p>	<p><b>ECO MODE</b></p> <p>The Eco Mode menu item allows you to choose between ON and OFF.</p> <p style="text-align: center;"><b>ON and OFF</b></p> <p>With ECO mode ON, the device automatically switches to sleep mode during music pauses longer than 9 minutes to save energy. See chap. 5.2. Ecomode</p>
 <p>MENUE <span style="margin-left: 100px;">ON</span> <span style="margin-left: 100px;">OFF</span> <span style="float: right;">RETURN</span></p> <p>LANGUAGE: EN      INPUT: RCA</p> <p>TUBES: KT120      POWER: LOW</p> <p>ECOMODE:      <b>MUTE:</b></p> <p>BIAS:      WATTMETER:</p>	<p><b>MUTE (MUTING)</b></p> <p>The "Mute" menu item lets you choose between On and Off:</p> <p style="text-align: center;"><b>ON and OFF</b></p> <p>The muting function disables the RCA and XLR inputs. In this mode, signal cables can be connected or replaced without having to turn off the amplifier. See chap. 5.3. Muting function</p>
 <p>MENUE <span style="margin-left: 100px;">ON</span> <span style="margin-left: 100px;">OFF</span> <span style="float: right;">RETURN</span></p> <p>LANGUAGE: EN      INPUT: RCA</p> <p>TUBES: KT120      POWER: LOW</p> <p>ECOMODE: ON      MUTE: ON</p> <p><b>BIAS:</b>      WATTMETER:</p>	<p><b>BIAS</b></p> <p>The BIAS indicator lets you check whether all tubes are operating within the normal range. (green LED)</p> 
 <p>MENUE <span style="margin-left: 100px;">ON</span> <span style="margin-left: 100px;">OFF</span> <span style="float: right;">RETURN</span></p> <p>LANGUAGE: EN      INPUT: RCA</p> <p>TUBES: KT120      POWER: LOW</p> <p>ECOMODE: ON      MUTE: ON</p> <p>BIAS:      <b>WATTMETER:</b></p>	<p><b>WATTMETER</b></p> <p>You can monitor the current music power output using the wattmeter scale.</p> 

## 4. THE OPERATION

### 4.2. Rear panel JUBILEE Class A

#### 4.2.1. Rear panel JUBILEE Class A without remote

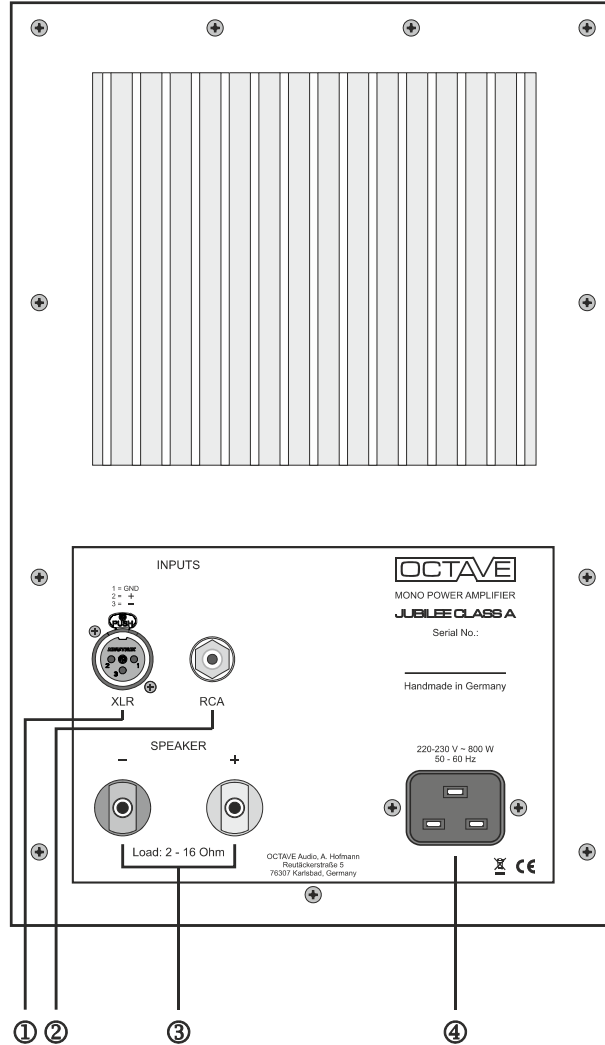

#### Legend

①	<b>XLR-Input</b>	Balanced Line Level Input for connection to the preamplifier with XLR cable. Pin 1: Ground, Pin 2: +, Pin 3 -
②	<b>RCA-Input</b>	RCA Line Level Input for connection to the preamplifier with RCA cable
③	<b>Loudspeaker Outputs</b>	Speaker cable terminals. When connecting the amplifier to the speaker, ensure that the red terminal of the amplifier (positive terminal) is connected to the positive terminal of the speaker and the black terminal (negative terminal) is connected to the negative terminal of the speaker. <b>The speaker outputs are compatible with 4 mm and spade connectors.</b>
④	<b>Mains input</b>	Mains input, IEC - C 19 cold device socket

## 4. THE OPERATION

### 4.2. Rear panel JUBILEE Class A

#### 4.2.2. Rear panel JUBILEE Class A with remote activation

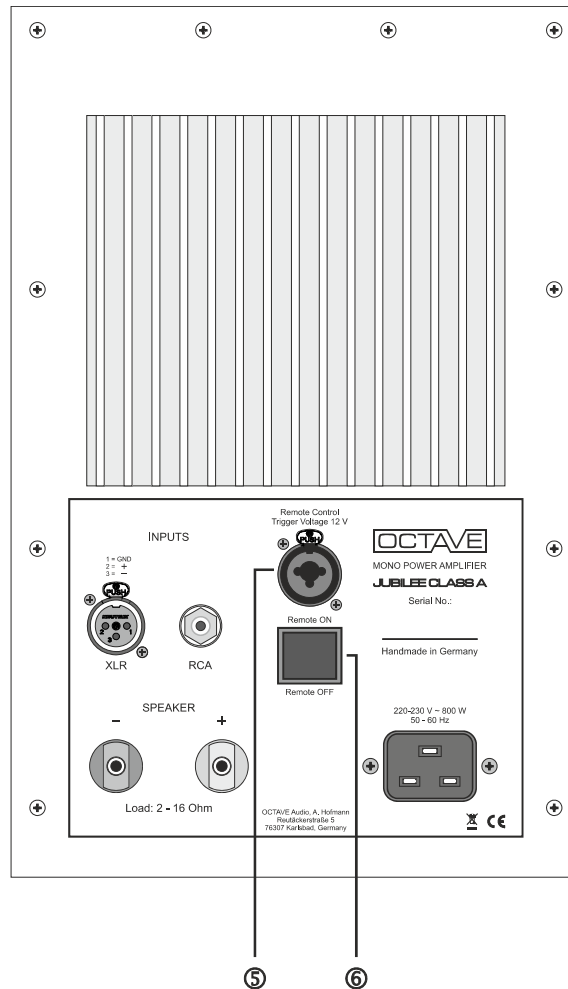

#### Legend

- |   |                                 |  |
|---|---------------------------------|--|
| ⑤ | <b>Trigger voltage Input</b>    | 6,3 mm connector; 12 Volt DC trigger voltage for power on  |
| ⑥ | <b>Remote activation switch</b> | Remote ON: Remote function active<br>Remote OFF: Remote function disabled<br>The remote function does not bypass the mains power switch. For correct function the mains power switch must be in position ON. The amplifier can be switched off at any time using the power switch. |

## 5. ADVANCED FUNCTIONS

### 5.1. Soft-Start, Inrush Current Limitation

The driver and output tubes, as well as the main power supply of the JUBILEE CLASS A, are controlled by the **Power Management System**, a logic controller, and start up in a time-controlled sequence (soft start). This reduces the inrush current of the unit itself and protects important components from excessive stress during power-up (tubes, capacitors, rectifier, switches, etc.). This increases the lifespan not only of the tubes: all components in the power section benefit from this measure.

The soft start function is always active for 70 seconds after the unit is switched on. No music playback is possible during the soft start.



During this phase, the menu cannot be accessed via the display. This is only possible after the start-up phase has elapsed.

During the Soft-Start-phase, adjusting the BIAS is not possible



### 5.2. Eco Mode (Power Saving Mode)

Eco Mode is an energy-saving and safety function that automatically shuts down the tube section of the unit during periods of inactivity (longer than 12 minutes).

Activated Eco Mode reduces power consumption and protects the output tubes. When a signal is received, the JUBILEE CLASS A automatically returns to the preset operating mode.

Note:

If the JUBILEE CLASS A is switched on with Eco Mode activated, it will first power up completely. If no music is played, it will shut down after 10 minutes. Eco Mode is not a standby function in the traditional sense, as the JUBILEE CLASS A remains operational with its safety electronics activated. While the power supply to the tubes is switched off, there is no danger from the output stage. However, as a precaution, the unit should be disconnected from the mains power supply during thunderstorms with strong lightning strikes or while on vacation.

The switching threshold of the Ecomode is less than 10 mV signal level at the output of the final stage, this corresponds to approximately < 400  $\mu$ W output power.

### 5.3. The Mute Function

The muting function "ON" switches off the signal inputs and the speaker output. In this mode, signal and speaker cables can be connected or replaced without having to switch off the power amplifier. To listen to music, the mute function must then be switched back to "OFF".

## 5. ADVANCED FUNCTIONS

### 5.4. Operating mode Class A – Class A/B

The Power Low and High switches in the Jubilee Class A primarily toggle between Class A and Class AB operating modes.

Some music lovers find Class A operation of a power amplifier to be more sonically authentic and organic. In particular, loudspeakers with higher efficiency harmonize very well with Class A power amplifiers.

However, by design, Class A power amplifiers have a limitation in maximum output power, which is very pronounced in single-ended Class A amplifiers. Power outputs in the range of 7–30 W are typical.

We wanted to overcome this limitation because the vast majority of dynamic loudspeakers require higher output power from the power amplifier to reproduce music in its full dynamic range.

This is where the new V 70 Class A comes in. In the V 70 Class A, the Class A concept has been transferred to our push-pull pentode design. While push-pull power amplifiers can achieve higher power and stability in Class A mode than single-ended amplifiers, However, the performance, and therefore the sonic characteristics, at higher power levels leave much to be desired. Especially with multi-way loudspeakers exhibiting impedance variations, sonic dips occur that severely limit, or even preclude, the use of these amplifiers.

This is precisely where the further development of our push-pull Class A amplifiers comes in. The "dynamic Class A current control" was developed. This system stabilizes the Class A mode of the power amplifier depending on the speaker load.

The power amplifier operates stably, largely independent of the loudspeaker used and its impedance curve. This allows for a significant increase in peak output power without any loss of sound quality.

Class A is thus available for the first time with a wide variety of loudspeaker types.

The success and unique sound of the Jubilee 300 B – Single Ended and the V 70 Class A form the basis for the "Jubilee Class A."

In Power Low Class A mode, the Jubilee Class A achieves 160 W RMS and approximately 200 W dynamic peak power.

Despite this high power output, the Jubilee Class A incorporates a "Power High" A/B mode.

In this mode, the Class A component is reduced, and the power supply switches internally. This results in a power output of 260 W RMS and a peak power of 300 W in A/B mode. achieved.

The world of loudspeakers, with all its technological and sonic differences, makes the search for the "ideal" amplifier anything but easy.

Some loudspeaker designs harmonize better with A/B power amplifiers for sonic reasons. The reasons for this are complex and cannot simply be deduced from a loudspeaker's technical specifications.

Therefore, this High Power mode was integrated into the Jubilee Class A to offer a power amplifier with the highest possible flexibility.

## 5. ADVANCED FUNCTIONS

### 5.5. BIAS control

The BIAS meter is used to check the quiescent current of the output tubes. Correct BIAS setting for all tubes is crucial for the amplifier's sound characteristics and the tubes' lifespan. Therefore, the JUBILEE CLASS A incorporates a BIAS meter, allowing you to check the BIAS without additional measuring equipment.

Due to the automatic BIAS setting of the JUBILEE CLASS A circuit, the green bar should always be displayed in the BIAS meter when using selected CLASS A output tubes. If one of the output tubes deviates significantly from the BIAS setting, and no color (yellow or red) is displayed, it should be replaced.

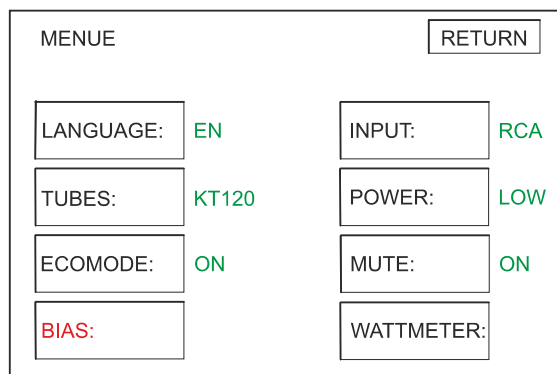

The bias indicator shows you the condition of the output tubes. If all six output tubes are in good condition, all six indicators will turn green. If an indicator turns red, shows no color at all, or remains yellow, that tube should be replaced.

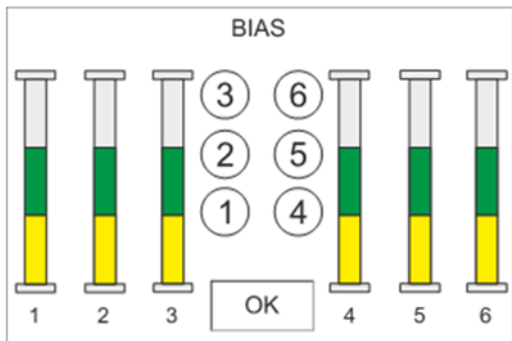

→ The bias indicator remains in the green zone:  
All tubes are OK.

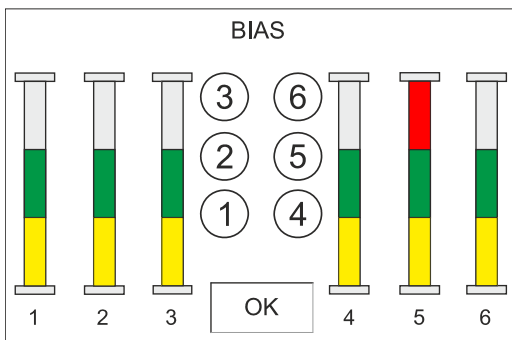

→ The bias indicator goes into the red zone for one tube:  
Tube No. 5 is defective. It must be replaced.

## 5. ADVANCED FUNCTIONS

### 5.5. BIAS control

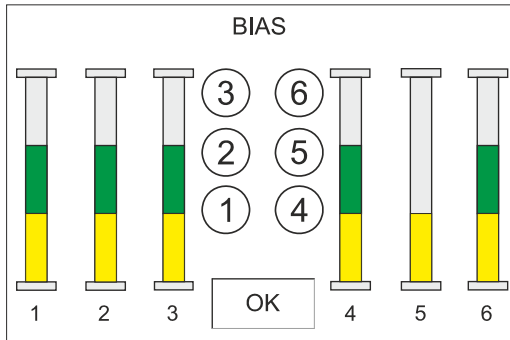

The bias indicator on one tube only goes up to the yellow area:  
 Tube No. 5 is working, but the current is too low. That means it needs to be replaced.

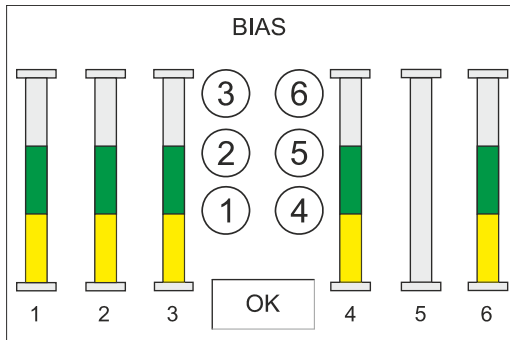

The bias indicator shows no color at all for one tube:  
 Tube No. 5 is dead. It must be replaced.

### 5.6. The Electronic Protection System

The Protection System is an electronic safety and monitoring system. In the event of a fault, this system electronically shuts down the power section of the JUBILEE CLASS A.

The purpose of the Protection System is to protect the unit from consequential damage caused by any type of overload and to protect the output tubes from overcurrent caused by overdriving and short circuits in the speaker cables.

The activation of the Protection System is indicated by the red text "Security mode" (Protection) on the display.

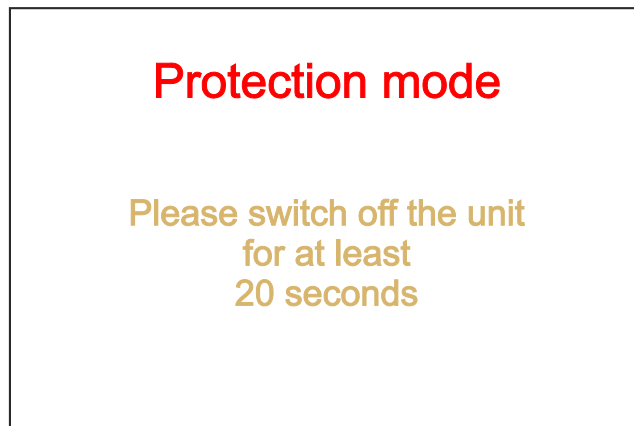

## 5. ADVANCED FUNCTIONS

### 5.6. Electronic Protection Circuit System

Once the protection system is activated, music playback is no longer possible. Bias adjustment is also no longer possible.

The following conditions can trigger the protection system:

- Overdriving the JUBILEE CLASS A with excessive levels and a strong low-frequency signal component
- Short circuit in the speaker cables with a high listening level.
- Defect of one or more of the output tubes.

After the protection system has been activated, the JUBILEE CLASS A can only be restarted by switching the power switch off and on again. The unit should be allowed to cool for 5 minutes before being switched back on. The cause of the fault should be identified and rectified as far as possible. (See Chapter 9 "Troubleshooting")

When the unit is switched back on after a protection system activation, the BIAS display appears first, not the Start – Warm Up window.

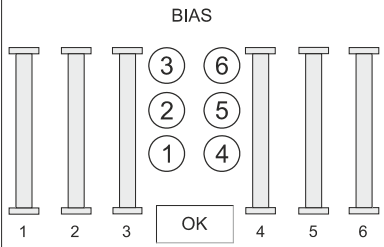
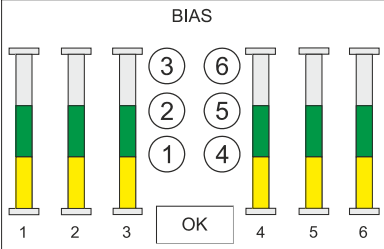
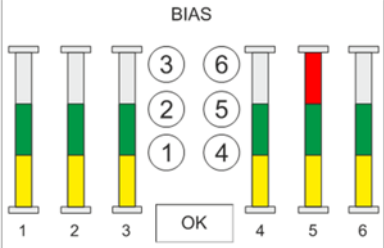
<p>1) The bias indicator initially appears without color.</p> <p>This is for monitoring the output tubes. During the power amplifier's startup, the indicator changes according to the operating state of the output tubes.</p>	
<p>2) After the warm-up phase (70 seconds), the display should show green for all output tubes. If the fault was known beforehand and has been rectified (e.g., a short circuit in the speaker), the BIAS display can be switched off with OK; the normal start-up process will then be shown on the display.</p>	
<p>If a tube is defective, this can be detected on the display by the display rising into the red zone or by instabilities in the bias of an output tube (yellow zone only). (See Chapter 6.3)</p> <p>This allows a potentially defective output tube to be detected during startup. In this case, the device should be switched off again and the affected output tube must be replaced.</p>	

## 6. TUBES

### 6.1. Removing the Protective Grille

Operating the device without the protective grille is prohibited and at your own risk!  
 Removing the protective grille:  
 See chap. 3.3. Removing the grille

### 6.2. Tube Diagram

See chap 3.4. Inserting the power tubes

#### 6.2.1 Tube Diagram: Output Tubes

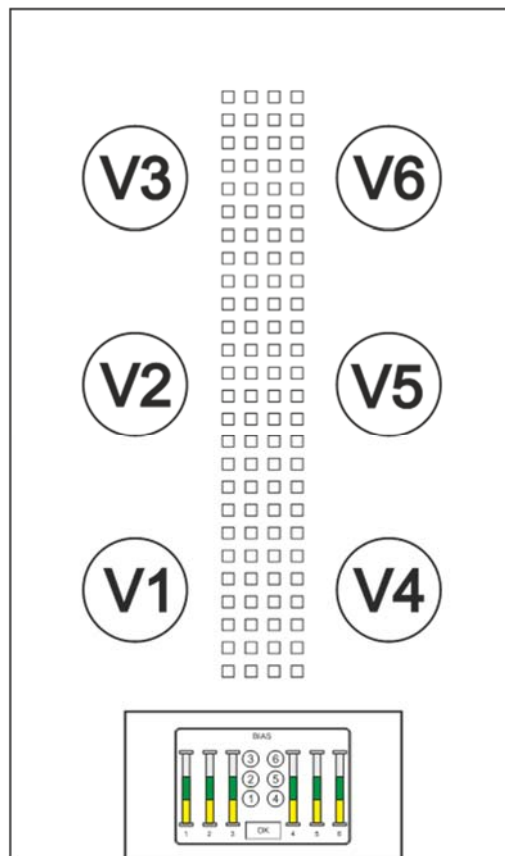

Output tubes: V1 – V6:

Standard KT120 tubes, selected as a set.

Alternatively, the KT150 or KT170 can also be used



**Please use only these three types of tubes.**  
**Other tubes, such as KT88 / 6550, must not be used because they are too poor.**



## 6. TUBES

### 6.2.2. Tube layout driver tubes

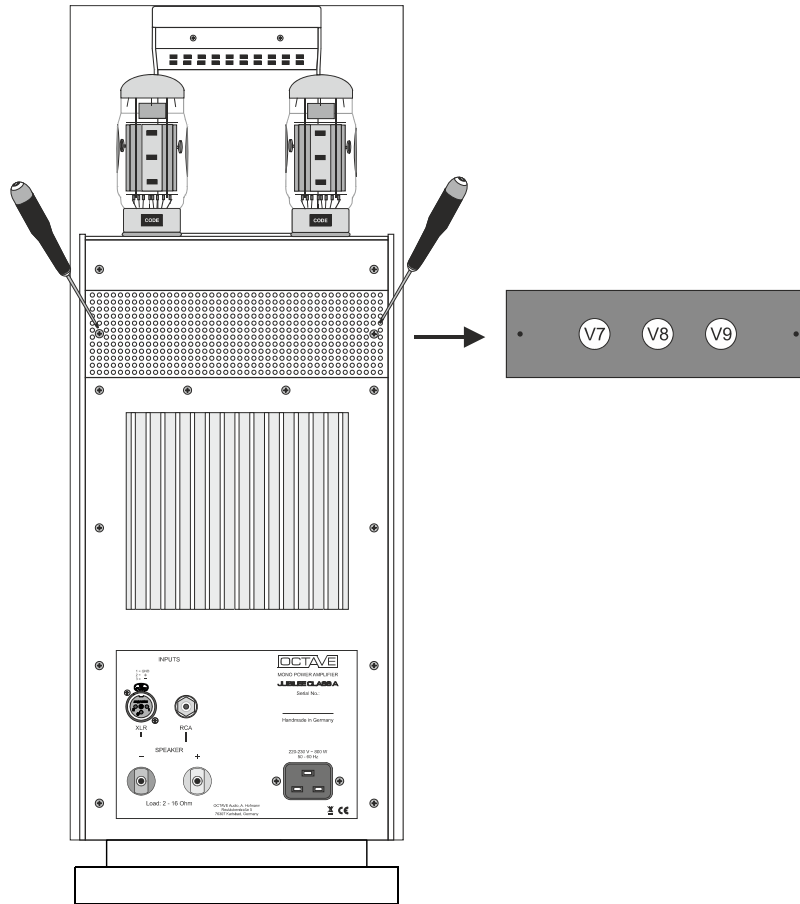

Driver tubes: V7 + V8 12 AU 7 Tung Sol, (ECC82, ECC 802, 5814, 6189)  
 V9 12 BH 7 JJ

#### Procedure

1. Disconnect the device from the mains power supply and secure it against accidental reconnection (e.g., by unplugging it).
2. Using the supplied 1 x 2 mm Allen screwdriver, completely unscrew the two Allen screws on the right and left of the grille on the back of the power amplifiers.
3. Remove the grille. You will now see the three driver tubes.
4. You can now carefully jiggle the old driver tubes out and insert new ones.  
 Tube No. 8 should be a selected tube with identical specifications for both internal systems. Ideally, tube No. 8 in the other power amplifier stage should have the same specifications to eliminate channel differences.

## 6. TUBES

### 6.3. Replacing the tubes

#### WARNING TERM



→ Before opening the protection grill, switch OFF the device, disconnect the mains power plug and wait for 10 Minutes.

#### General procedure:

Switch off the amplifier and allow it to cool down for 10 minutes.  
Remove the old tubes and fit the new ones.

#### Inserting new driver tubes

New driver tubes can be put into operation after replacement without further action or adjustment.

#### Inserting new power tubes:

##### Procedure

1. After switching the device back on with new output tubes, check that the output tubes are correctly seated and mark any old or defective output tubes.
2. Switch on the device. After the start-up phase, the BIAS reading for each output tube should now be displayed as "green".
3. After a 30-minute warm-up phase, the bias can be checked again. Normally, no deviations in the bias are to be expected after the output tubes have reached their operating temperature.
4. Now the protective grille can be put back on.

### 6.4. Running in

All OCTAVE equipment is subject to a 48-hour continuous operation test at the factory to burn in the tubes and the unit. The tubes are preselected and matched for the use in each particular model. The Output tubes have a match code on the socket. Tubes with the same or +/- 0.5 match code ensure low channel tolerances of +/- 0.2 dB.

Old and even new tubes can take up to one month to run in and start sounding their best.

Daily use is beneficial in speeding up this process but is not mandatory. Continuous operation does very little to help reduce the running-in time and is therefore not recommended.

### 6.5. Tube service life

- Thanks to the protection circuits and soft-start electronics, the output tubes in your amplifier should achieve a service life of up to 3 - 5 years.
- Driver tubes can be used up to 10 years.
- Because tubes have different service lives, you will never have to renew the entire tube set at the same time. You can replace output tubes individually if you get Class A tubes with the same match code/specs.
- Some tubes require a long time (up to 300 hours) to achieve their optimum sound quality.

## 7. TROUBLESHOOTING

### ■ Hum

Humming often occurs when multiple devices in a system are grounded. This is usually the case with tuners, satellite receivers, video equipment, and network connections, as these devices are connected to a high-gain antenna or cable. However, the high-gain antenna and cable are also grounded, creating a ground loop through the antenna input. The JUBILEE CLASS A is also grounded. However, the JUBILEE CLASS A is equipped with a special technology that reliably prevents ground loops. Should ground loops still occur through tuners or televisions, the use of common-mode chokes for the antenna connections is recommended. This will eliminate all ground loops.

#### **Humming when connecting the power amplifier via XLR:**

When connecting the power amplifier to the preamplifier via XLR, ensure that all three poles of the XLR cable are connected.

### ■ Switching Interference

Older refrigerators and 12V halogen lamp systems can generate significant radio interference when switched on and off. Depending on the house's electrical system, this interference can be heard as crackling in the system's speakers.

Remedy: The only solution is a central power strip for the entire system, possibly with a filter. However, an inexpensive industrial power line filter in the refrigerator's power cord may eliminate the interference more effectively.

### ■ Uneven Volume Levels or Distortion in Limited Frequency Ranges

Uneven volume levels or distortion in certain channels are very rarely due to defective tubes. Signal cables are often the culprit.

Remedy: Disconnect all unnecessary devices/RCA cables from your preamplifier. Check the speaker and signal cables, for example, by swapping the channels. If the problem moves, for example, from left to right, or disappears altogether, the cause can usually be identified.

### ■ Tube Defect

Three different failure modes can occur with output tubes:

1. Broken filament: The tube is no longer glowing. The bias indicator is not showing any color..
2. Defective cathode layer: The tube glows, but no current flows. This fault is indicated on the bias meter by a reading of 0 and no color.
3. Short circuit within the tube: Normally, the electronic fuse trips, and the red protection indicator light illuminates.

With faults 1 and 2, the device still plays, but the channel with the defective tube is quieter. Distortion occurs at high listening levels; at low levels, you might not even notice the defective tube.

With fault 3, the device is usually switched off electronically. Depending on the tube fault, background noise may be audible before the shutdown, but this will not cause any damage. The faulty tube can be located by removing one output tube at a time, or by observing the bias with the bias indicator switched on.

This test should only be performed by qualified personnel.

## 8. FAQ

### 1. Can you operate the JUBILEE Class A when no loudspeakers are connected?

Yes. The JUBILEE Class A, like all OCTAVE amplifiers, is fully protected against open circuit operation, i.e. the amplifier will come to no harm if it is operated without loudspeakers connected and the input level is in the magnitude of normal listening levels.

### 2. How do you recognize a faulty tube?

See troubleshooting.

### 3. Is there a loss of sound quality as tubes age?

No. Tubes normally sound the same throughout their service life. Our soft-start technology contributes greatly to extending the service life of tubes. You can tell when an output tube has reached the end of its useful life: it becomes impossible to adjust it correctly. Driver tubes cannot be checked, but these will generally last up to 10 years.

### 4. Does the JUBILEE Class A have to have all of its tubes fitted?

In principle, the JUBILEE Class A will also operate without output tubes. Of course, it is not possible to play music under these circumstances.

For test purposes, or as a temporary measure, one channel may be fitted with just a single power tube, although its power output will - of course - be reduced. The amplifier will come to no harm if it is operated continuously like this.

Operation without driver tubes is also possible for test purposes, although, for obvious reasons, music playback is not possible.

### 5. What is the significance of loudspeaker impedance and efficiency?

The impedance and efficiency of modern loudspeakers is not an issue for OCTAVE amplifiers. The often-quoted damping factor is not normally a guarantee that an amplifier will exert tight control over the loudspeakers. In practice, speakers of 85 dB efficiency and above are suitable for use with tube amplifiers. The high stability of the OCTAVE power amplifier technology even allows the use of speakers whose impedance dips as low as 2 ohms.

### 6. What cables are suitable for tube power amplifiers?

The cable manufacturers are now offering cables that have supposedly been designed specifically for tube amplifiers. Although such cables may be of good quality, there is no need to use special cables with tube amplifiers. Speaker cable can exhibit high values of capacitance and inductance, and tube power amplifiers deal with such loads better than transistor power amplifiers. The only exception would be if you want to use a tube pre-to-power amp interconnect cable longer than 5 meters. In that case, a low capacitance cable would be advisable.

## 9. TECHNICAL DATA

### Construction:

- Double-sided, through-hole plated special high-voltage circuit boards with 75µC copper plating
- Specially selected and burned-in long-life tubes
- Professional low-inductance power supply capacitors, LH-grade 105°C
- C19 high-current mains input with RF filter

Technical Specifications	
<b>Output power:</b>	160 W in Class A – Power LOW, 280 W in Class A/B- Power HIGH
<b>Power bandwidth:</b>	20 Hz - 80 kHz / - 3 dB
<b>Gain:</b>	29.5 dB into 4 ohm loudspeakers
<b>Signal to Noise Ratio:</b>	Gain High > 100 dB @ 20 W
<b>Input sensitivity:</b>	Power LOW: 1 V for P max Power HIGH: 1.3 V for P max
<b>Damping factor:</b>	4.5
<b>Inputs and Outputs:</b>	RCA, XLR Inputs 4 ohms loudspeaker outputs
<b>Pin configuration XLR</b>	1 = ground, 2 = +, 3 = -
<b>Tubes</b>	Output tubes: 6 x KT120 Driver tubes: 2 x 12 AU 7 Tung Sol, 1 x 12 BH 7 JJ
General Data	
<b>Power consumption</b>	400 W each power amplifier, BIAS MED
<b>Operating temperature range</b>	10 – 25 ° C
<b>Weight:</b>	52 kg / pc
<b>Dimensions</b>	24 x 66 x 40 cm (W x H x D)

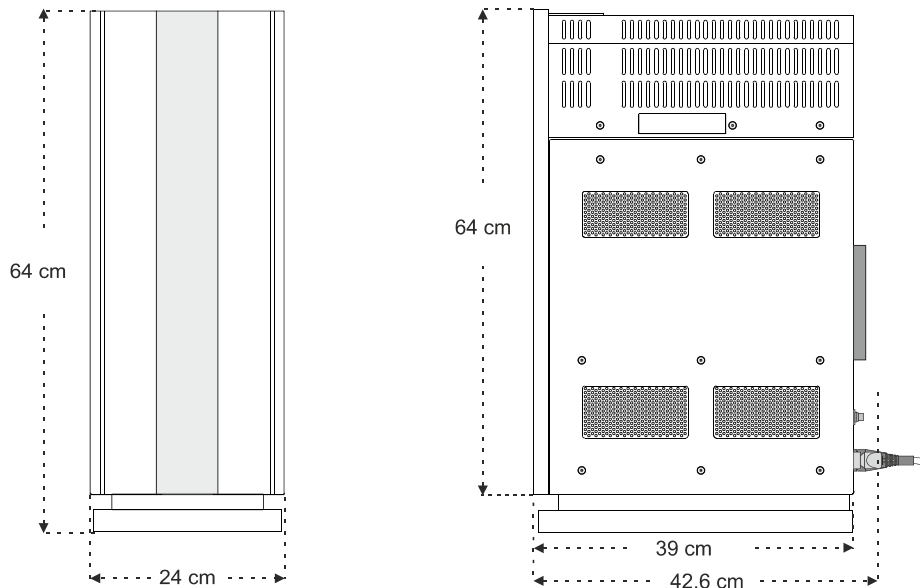



We reserve the right to alter and improve the specifications in pursuit of better. OCTAVE logo is a registered trade mark of Andreas Hofmann. Copyright by Andreas Hofmann

OCTAVEAUDIO T. +49 (0) 7248 3278  
ANDREAS HOFMANN F. +49 (0) 7248 3279  
REUTAECCKERSTR. 5 INFO@OCTAVE.DE  
DE-76307 KARLSBAD WWW.OCTAVE.DE