

OCTAVE

JUBILEE MONO
ULTIMATE

Owner's Manual

English

FOREWORD

I wish to personally thank you for choosing unique OCTAVE products and congratulate you on your purchase of your new

Jubilee Mono Ultimate

Here at our head office in Karlsbad, right on the edge of the Black Forest, we have been designing and building high quality, long-lasting hi-fi equipment for over 20 years that will – quite literally – provide you with hours of musical pleasure for many years to come.

Today's loudspeakers and high-resolution source equipment continue to be very demanding of amplifiers. As a result, achieving improved amplifier sound quality requires greater levels of technical innovation than ever before.

OCTAVE specializes in the ongoing development of upgradeable circuit designs and has earned a reputation over recent years as a world leader in the field of high-end tube amplifier design. Thanks to our years of experience and our in-depth understanding of amplifier technologies and their side effects, OCTAVE is able to achieve a musical quality and degree of reliability that seemed impossible or unaffordable only a few years ago

I trust that you will enjoy many hours of wonderful music with your OCTAVE amplifier.



Andreas Hofmann
Designer and Owner of OCTAVE Audio

CONTENTS

	Page
Foreword	
1. Introduction	4
1.1. What makes OCTAVE amplifiers special	4
1.2. Jubilee Mono Ultimate product description.....	5
2. Safety instructions.....	7
2.1. Before you begin.....	7
2.2. Placement	8
2.3. Warranty	8
3. Getting started	9
3.1. Unpack and check the content	9
3.2. Removing the protective cover	9
3.3. Position the devices in the listening room	10
3.4. Installing the power tubes	11
3.5. Recommended starting procedure	12
4. Operating components	14
4.1. Jubilee Mono Ultimate top control panel.....	14
4.2. Jubilee Mono Ultimate rear panel	16
5. Advanced functions.....	18
5.1. Bias measurement facility.....	18
5.1.1. How the bias works.....	19
5.1.2. How to set the bias	19
5.2. The electronic protection system	20
5.3. Soft Start, inrush current limitation.....	20
5.4. Power Pre Selector	21
5.5. Muting function.....	21
5.6. Remote operation	21
5.7. Ecomode	22
6. Tubes	23
6.1. Tube layout	23
6.2. Replacing the power tubes	24
6.3. Tube service life.....	24
6.4. Replacing the driver tubes	25
7. Troubleshooting	26
7.1. General troubleshooting tips.....	26
7.2. Identifying defective tubes	27
8. Technical data and dimensions	28
9. Technical data, diagrams.....	29
10. FAQ.....	31

1. INTRODUCTION

1.1. What makes OCTAVE amplifiers special

- Sound** The design goal of OCTAVE amplifiers is honest, natural sound reproduction. The sound characteristics of an amplifier are derived from the sum of all its parts. Tubes themselves do not only guarantee high quality sound.
- Amplifier design** The frequency range and output resistant limitations of classic tube designs are evident as soon as you connect the amplifiers. These designs often only perform to their full potential when they are used with special loudspeakers. OCTAVE amplification and power supply technology has largely overcome these well-known problems. Thanks to their unique output stage design, they will maintain their optimum sound quality with virtually any loudspeaker, irrespective of the cables.
- Control + monitoring** OCTAVE employs the latest electronic circuit designs to create the best possible operating conditions for the tubes, and thus for the amplifier itself.

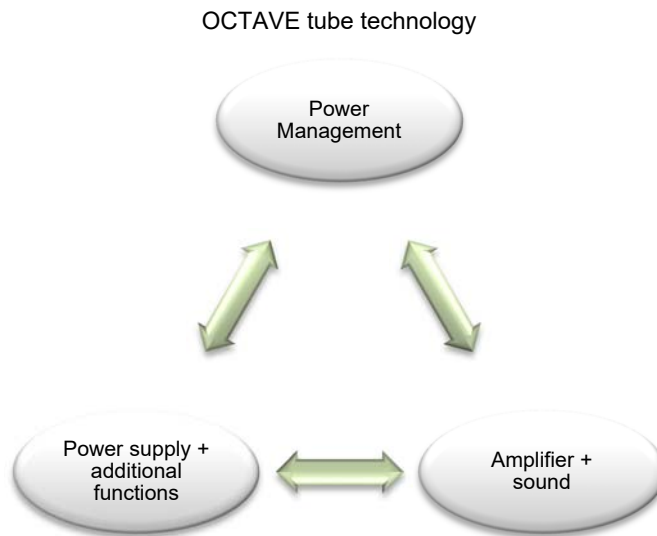

OCTAVE amplifiers are equipped with a proprietary control and monitoring system we call **Power Management**. This is an “electronic brain” within the amp that regulates and controls all of the amplifier’s functions. It includes the **Soft Start Electronics** that gently ramp up the heating and supply voltages to minimize wear and tear on the components. In the event of a problem, the Power Management’s **protection system** disconnects the unit from the power supply. Power Management helps us to achieve a completely consistent sound while at the same time ensuring the total reliability of our products.

- Hand built** OCTAVE amplifiers are hand built and individually 100% tested. They are designed and developed by Andreas Hofmann. The company has its own winding department, in which all transformers are especially custom-wound for each amplifier.
- Made in Germany** OCTAVE devices are 100% made in Germany. Our staff is highly qualified and motivated. We work with specialized suppliers from our area for mechanics. We only use the best, most durable electronic components. Since we develop and manufacture our amplifiers ourselves, we can repair any Octave device, no matter how old it is. Sustainability and longevity have been our banner since 1968

1. INTRODUCTION

1.2. Jubilee Mono Ultimate product description

Jubilee Mono Ultimate: not just an Evolution, a Revolution

The Octave Jubilee Mono power amplifiers were introduced in 2003, four years after the venerable Octave Jubilee preamplifier made its debut. Together, they represented the pinnacle of Octave's offerings in both performance and technical excellence for well over a decade.

With 250W of power on offer, immense power reserves, and Octave power management for rock-solid performance and reliability, the Jubilee Mono represented a milestone for high-end tube amplifiers. In 2016, the design and performance were advanced further with the introduction of the Jubilee Mono SE (Special Edition), featuring eight KT 120 tubes generating 400W of output power per channel.

Today, Octave is proud to announce the revolutionary successor to its flagship Jubilee amplifier model: the **Jubilee Mono Ultimate** the new crown jewel of the Octave amplifier range. **Jubilee Mono Ultimate** is the most sophisticated power amplifier design in the company's portfolio to date, featuring a multitude of new technologies and eight KT 170 tubes delivering 440W per channel.

The fundamental goal in designing the **Jubilee Mono Ultimate** was to provide an extreme extension of both the bass range and the amplifier's overall power bandwidth. Done successfully, meeting these objectives serves to reduce distortion in the frequencies above and below the listening range, producing a sound that not only becomes more physical, but also more sensual, natural, and real.

Although not immediately obvious, the critical midrange in particular benefits considerably from a deep and accurate foundation. The influence that the lowest, nearly inaudible, low bass range has on the musicality of the midrange is significant. By meeting the design goals for the **Jubilee Mono Ultimate**, this foundation allows the body, harmonic continuity, and spatial depth and decay of every musical element to have its own distinct origin and ending – as it does in live music.

Now, more details on how we got there:

In most amplifier designs an increase in power bandwidth is usually associated with an increase in distortion. Andreas Hofmann, Octave founder and chief designer, developed an entirely new output transformer and a new, complimentary driver stage for **Jubilee Mono Ultimate** that nearly eliminates this effect, while still enabling a dynamic range that is second to none.

This is a path no one can take quite as Octave can, because we have been developing and manufacturing bespoke transformers ourselves using our own proprietary technologies for decades. Thanks to this, we were able to develop an enormous output transformer for **Jubilee Mono Ultimate** with the necessary power bandwidth of 10Hz to 100 kHz, with virtually no increased distortion. One of the ways this was achieved was through the use of proprietary windings to counteract the skin effect, which worsens the characteristics of the upper frequency range. **Jubilee Mono Ultimate's** output transformer windings feature more than double the separate speaker wires of conventional designs, thus increasing the surface area of the windings by 50% to combat skin effect. This contributes significantly to the incredible resolution and smoothness the **ULTIMATE** conveys in the midrange and high frequencies.

Otherwise, we employ four dedicated transformers designed specifically for **Jubilee Mono Ultimate**: the enormous output transformer, a separate transformer for the output tube heating, and a dual mains transformer system for the power section of the output stage. In addition to improving performance overall, this extensive and overbuilt design approach also allows the new KT 170 tubes to be operated optimally. The heavily modified **Jubilee Mono Ultimate** driver stage also contributes significantly to the expanded bandwidth and the increased naturalness. The extension of the **ULTIMATE's** power bandwidth, especially in the lower frequency range, is a new development approach in the spirit of the ideal of "No Loss of Fine Details - without Limits".

1. INTRODUCTION

By any measure, the **Jubilee Mono Ultimate** achieves a beauty of sound reproduction that is in no way inferior to the sound of a single-ended power amplifier, but without the inherent limits such designs impose.

With the Octave **Jubilee Mono Ultimate**, one will experience music as it should be - intense, emotional, and unforgettable.

What's new?

- KT 170 power tubes
- Oversized, ultra-wideband output transformer
- Loudspeaker (secondary) windings with multi-wire technology to minimize skin effect
- Advanced driver stage with optimized tube layout
- Mains transformer unit with 3 proprietary mains transformers
- New electrolytic capacitors with higher current delivery capability
- BIAS display and setting with significantly higher long-term precision
- Resonance-optimized base construction (8 mm aluminum, 2 mm steel, 50 mm X-MDF)
- Finishes: Black or Silver with wood (Macassar Ebony) or stone (Granite, Slate) inlay

Keyword: Performance

A simple analysis demonstrates that the power output of 440W also contributes to the elevated performance and extreme dynamic capabilities. When listening to music at a higher level, assuming a loudspeaker with an efficiency of approximately 88dB, approximately 25W are required.

This corresponds to the equivalent of 10 volts at the output of the power amplifiers. An impulse with the usual dynamics of modern recordings easily reaches three times this value. A factor of 3 results in 30 volts at the output of the power stage. 30 volts then corresponds to 225W of power at dynamic peaks. The high power is therefore important in order not to cut dynamic peaks or to avoid clipping distortions

2. SAFETY INSTRUCTIONS

2.1. Before you begin

In case of emergency: disconnect the plug from the mains supply

Never use an amplifier that is damaged or faulty. Make sure it has been labeled as defective and that it cannot be used until it has been repaired by a qualified service engineer. Make sure that there is easy access to the IEC socket and power cable.



Do not open the case

There are dangerously high voltages and hot tubes inside this equipment. To avoid a burn or the risk of electric shock, never allow anyone except qualified personnel to open the case or remove the grill.

Service and maintenance

For reasons of safety, please ensure that servicing, repairs and other modifications to OCTAVE equipment are carried out only by a qualified technician. Defective fuses should also only be replaced by a qualified technician. Always replace fuses with ones of the same type and rating. If your amplifier requires servicing, please ship or take your equipment directly to OCTAVE or to one of our authorized service centers.

Symbols and terms used in this instructions

	<p>Caution! Text passages marked with this symbol contain important information which must be observed if the amplifier is to operate safely and without problems.</p>
	<p>This information symbol marks text passages which provide supplementary notes and background information; they are intended to help the user understand how to get the best out of the amplifier</p>

Before connecting

Make sure that the voltage of your amplifier matches your local mains voltage.

Grounding

This amplifier is a protection class 1 device, (except 100V versions for Japan) with an earth conductor. Therefore a three-pin power cable with a protective earth contact must be used (included in the scope of delivery).

2. SAFETY INSTRUCTIONS

2.2. Placement

Location

- OCTAVE equipment is designed strictly for use in a dry domestic environment with a room temperature up to 25°C. Do not use it in open air or in damp environments!
- Never place plants or liquid-filled containers on your amplifier. Take care that objects do not fall or liquids are not spilled into the enclosure. Should this happen, disconnect the mains plug immediately and have your amplifier checked by a qualified service technician.
- Condensation may form if the amplifier is taken from a cold environment into a warm one. In this case, wait until the amplifier has reached room temperature and is dry before switching it on.
- Avoid installing the amplifier close to sources of heat, such as heaters, or anywhere that it may be in direct sunlight.
- Do not operate your OCTAVE amplifier near flammable materials, gases, or vapors. Avoid areas where there may be heavy accumulations of dust or where the amplifier may be subject to mechanical vibration.
- Place your OCTAVE amplifier on a stable, even surface.

Cover

Never operate the amplifier without the cover.

Ventilation

- Ensure sufficient air circulation around your amplifier. If you intend to install your equipment in a cupboard or a shelf unit, ensure that there is at least a 25 centimeter gap between the ventilation slots and the walls all around the amplifier.
- To prevent heat accumulation, the back of the cupboard should have ventilation holes.
- Do not rest the equipment on a soft surface such as carpet or foam sheeting.

2.3. Warranty

OCTAVE can only guarantee the safety, reliability and performance of this unit if modifications and repairs are carried out by specialized personnel and if the amplifier is operated in accordance with the instructions contained in this manual.

3. GETTING STARTED

3.1. Unpack and check the content

Scope of delivery	
-	2 x mono power amplifier Jubilee Mono Ultimate
-	2 x set of 8 power tubes KT170 packed separate
-	Power cord
-	Tools: 3 screwdrivers: Slot screwdriver size 3,5 for adjusting the bias (see chap 5.1.) Allen key size 2,5 for removing the cover [1] Allen key size 2,0 for removing the side panels [2]+ [3]
-	2 x 2 pc transportation handles
-	Octave cleaning cloth and soft gloves
-	Owner's manual with certificate

3.2. Removing the protective cover

Operation of the device without protective cover is not permitted and is at your own risk!

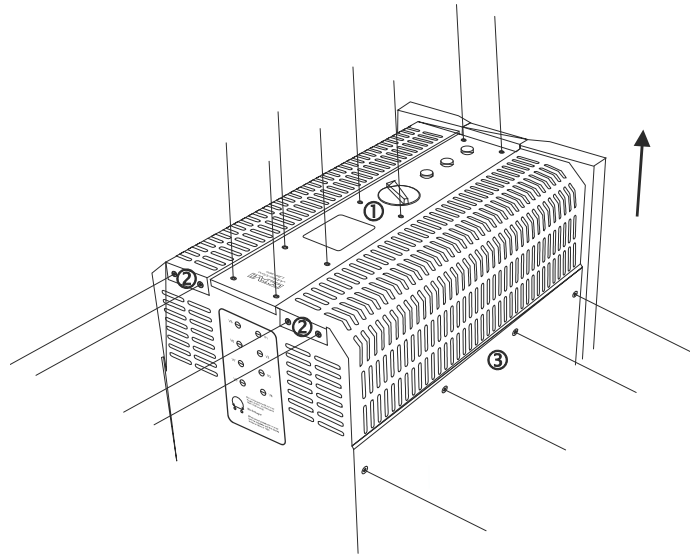

Procedure	
Step 1	For your own safety, make sure that the amplifier is not connected to mains
Step 2	Loosen the 8 x M3 Allen screws [1] of the top cover plate with a few turns (screwdriver size 2.5). You don't need to unscrew them all the way.
Step 3	Completely remove the socket head screws on the rear panel [2] with the Allen key 2,0
Step 4	Loosen the screws on the side panels [3] using the included 2.0 screwdriver. You don't need to unscrew them all the way
Step 5	Carefully pull the grille sideward and then upward to remove. Now you can see the handles, which are pre-installed to carry the amplifiers to their place in the listening room

3. GETTING STARTED

3.3. Position the devices in the listening room

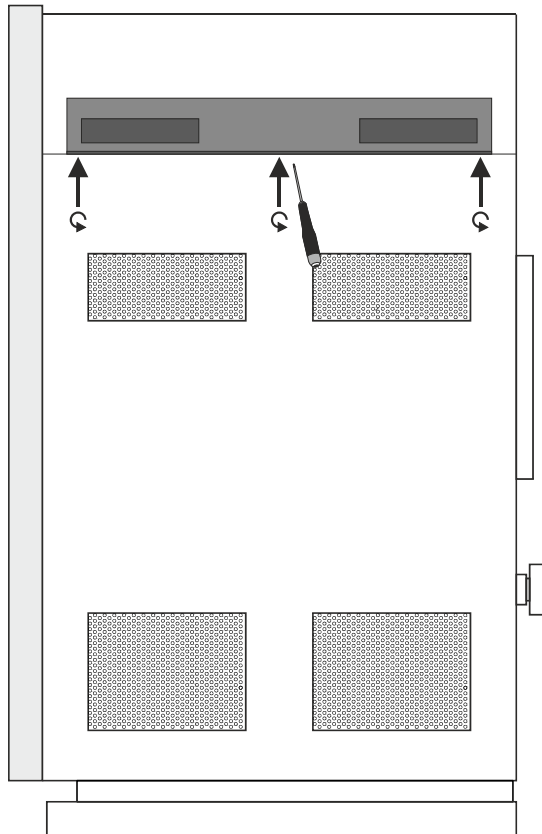

Procedure

- 1** Now please carry the amplifiers by the handles out of the package to their place in the listening room
- 2** If the position of the mono amplifiers is found, now you can uninstall the handles
Unscrew the three screws with the Allen key 2,0
Please save the handles in case the equipment needs to be moved again
- 3** Now you can install the tubes

3. GETTING STARTED

3.4. Installing the power tubes

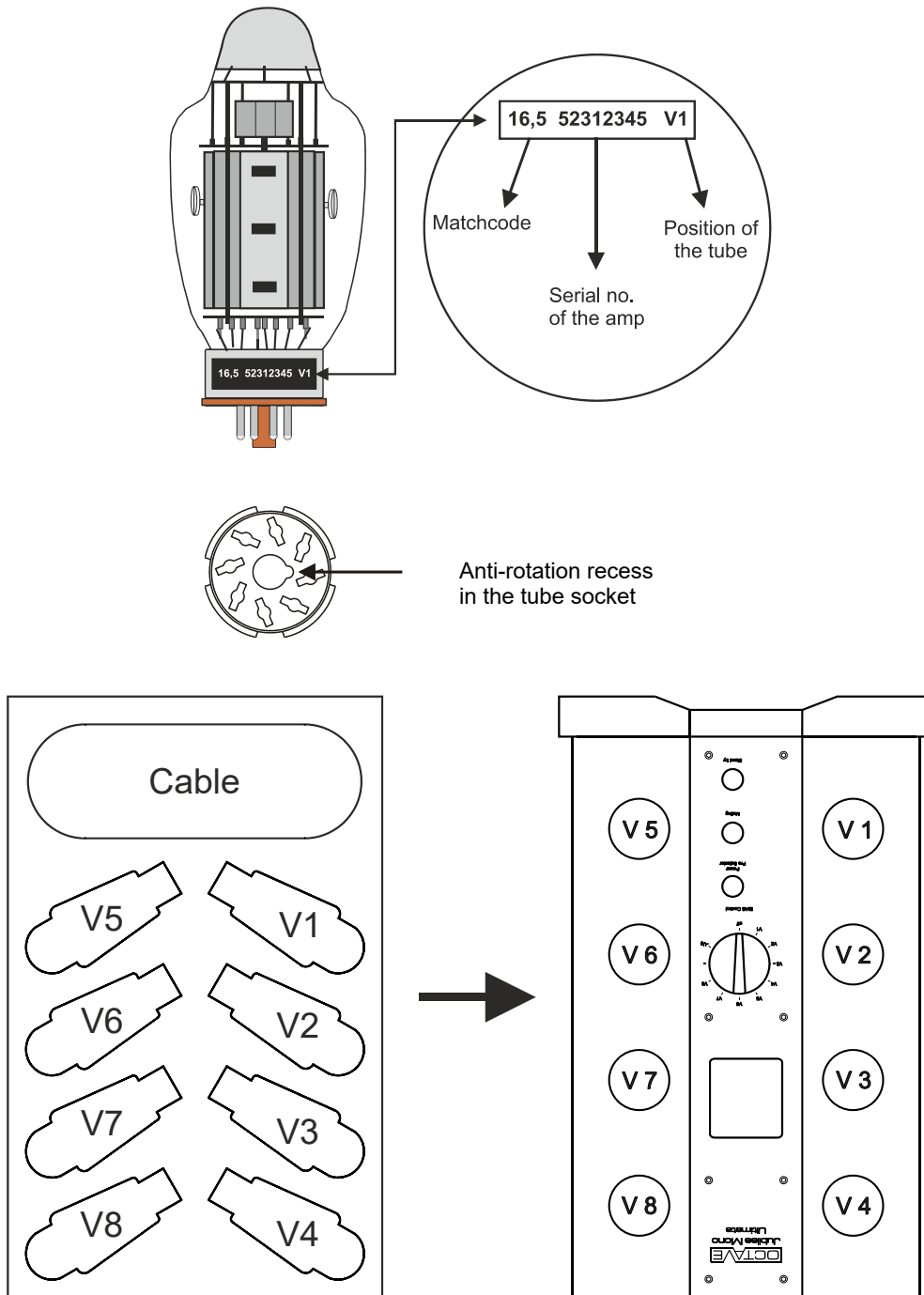

Procedure

- 1 Insert the power tubes into their sockets as shown in the drawing. Please only touch the tubes with gloves. (Included)
Make sure you have correctly positioned the anti-rotation lug on each tube.
- 2 Reinstall the cover grille again. (reverse order of 3.2.)

3. GETTING STARTED

3.5. Recommended starting procedure



Please note: Before you use your amplifier for the first time, we **strongly recommend** you to follow the procedure described in the following nine points, even if your dealer has already set the amplifier up for you. By checking these nine points, you will also familiarize yourself with the controls of your amplifier. Furthermore it will eliminate the possibility of user's error.

Procedure	
1	Connect the power amplifiers to an earthed wall socket using the power cable supplied. Exception Japan: There is no earth conductor
2	Connect your loudspeakers and preamplifier to the rear panel of the Jubilee Mono Ultimate amplifiers (see chap.4.2).
3	Push the power switch [8] above the power inlet socket on the rear panel (see chap. 4.2).
4	<p>Start phase</p> <p>Now push the power (stand by) button [1] on the top of the amplifier.</p> <ul style="list-style-type: none"> The unit will be switched on electronically via an internal relay and you will hear a clicking sound as the relay switches in. LED A and LED B light up in the display and - depending on the position of the Power Pre Selector - LED C or LED D. The display meter reads 000. (see chap.4.1 [5]). The start phase takes approx. 2 - 3 minutes. LED A (start LED) remains lit during this time. Since the amplifier is muted by default, LED B (muting LED) illuminates regardless of the position of the muting switch. Pressing the muting button makes LED B slightly brighter. <p>It is not possible to play music during the start phase. The Power Pre Selector switch should set to "high"; the blue LED D illuminates this function.</p>
5	After about two minutes, you will hear the sound of a second relay cutting in. This indicates that the output tubes are being heated up and they will begin to glow.
6	LED A and B go out once the start phase has been completed. Your amplifier is now ready for use. (You must deactivate the muting function, in case this function is ON, so that LED B is extinguished).
7	<p>Functional test Power Pre Selector in position "BIAS HIGH"</p> <p>Bias high is indicated by the blue LED D. The reading of the display is increasing slowly to a value of 500. Check the reading of each of the eight tubes by selecting them one by one. Deviations from 450 – 550 are acceptable.</p> <p>If a reading settles well below 400 or above 600; you need to roughly adjust this tube into this range using the appropriate bias control. After a warm-up period of up to 2 hours, you can then adjust the bias values more precisely so that all tubes have the same value (between 470 and 530).</p> <p>"Bias High" basic value: 500 "Bias High" maximum value : 1000</p> <p><i>This is now the default setting of the bias control, which should be maintained. The BIAS reading value in the setting BIAS Low is depending on the setting of the adjustments in Position BIAS High and cannot adjusted separately. If you make a correction in BIAS Low, you will forcibly adjust the setting of the High position.</i></p>



"Bias High" basic value: 500
"Bias High" maximum value : 1000

This is now the default setting of the bias control, which should be maintained. The BIAS reading value in the setting BIAS Low is depending on the setting of the adjustments in Position BIAS High and cannot adjusted separately. If you make a correction in BIAS Low, you will forcibly adjust the setting of the High position.

3. GETTING STARTED

8 *Functional test, muting*

If all values are correct, you can check the “Muting” function. When the muting function is active, not only the inputs are short-circuited to allow signal cables to be connected; the current to the power tubes is also reduced to nearly 0.

Checking the bias of the tubes while the muting function is ON, the reading of the display shows the value less than 50 of all tubes. The meter reading will gradually increase when you switch the muting function off. This soft start-up prevents pops and regulation noises being sent to your speakers.

When the muting function is active, the green LED B illuminates in the display and the LED next to the rear panel input selector switch goes out to indicate that the amplifier has been muted. ([12], rear panel).

9 *End of starting phase*

When you have confirmed that the amplifier is operating correctly and have made any necessary adjustments, you can go ahead and use the amplifier. However, the amplifier will not pass a signal to the loudspeakers if the red LED E illuminates during the start phase or while listening to music. This LED E lights up to indicate that the electronic protection circuit has switched off the amplifier. (see chap. 5.2)

In this case the BIAS reading value will fall to 0, no adjustment is possible.

4. OPERATING COMPONENTS

4.1. Jubilee Mono Ultimate top control panel

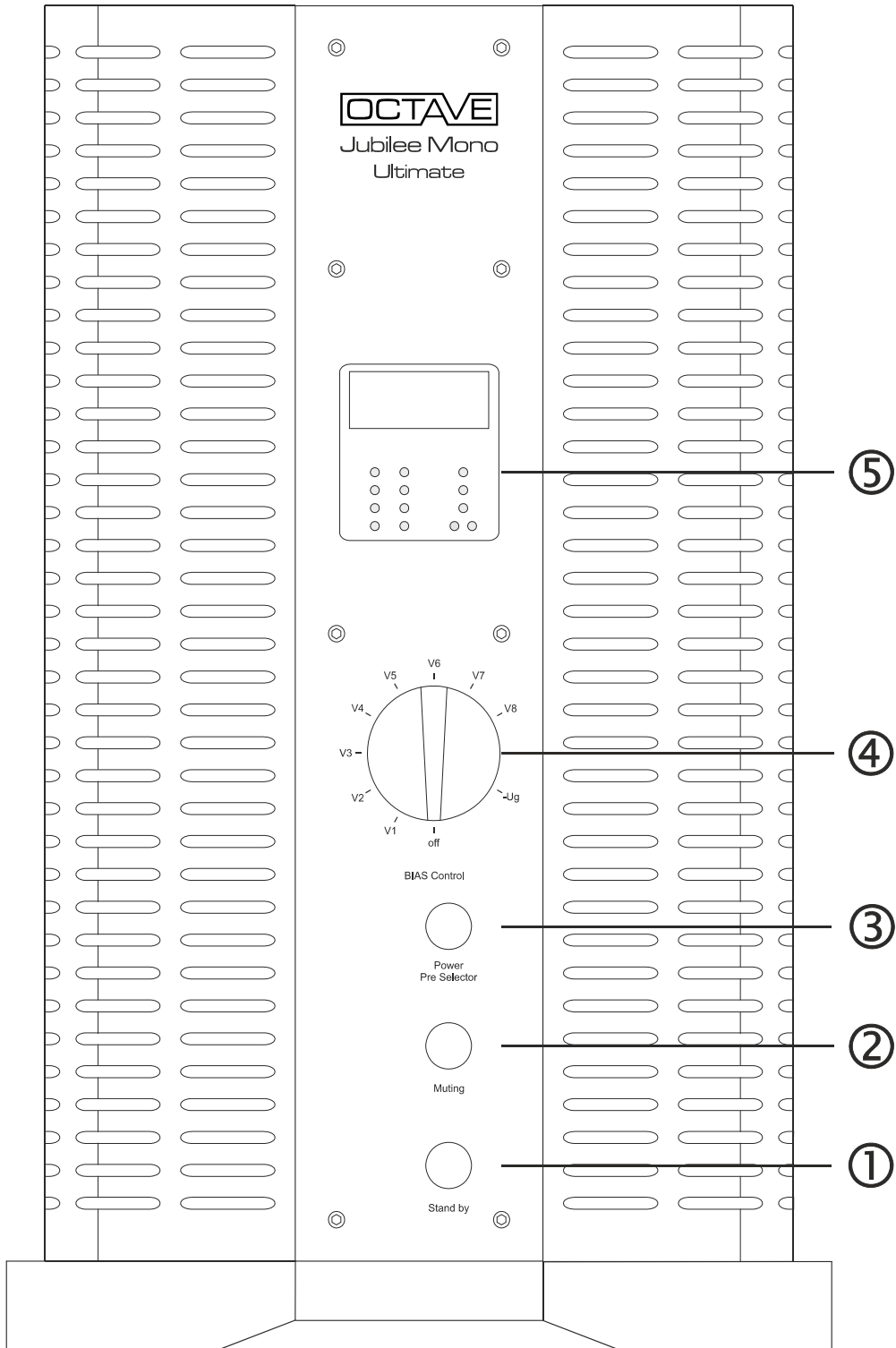

4. OPERATING COMPONENTS

4.1. Jubilee Mono Ultimate top control panel

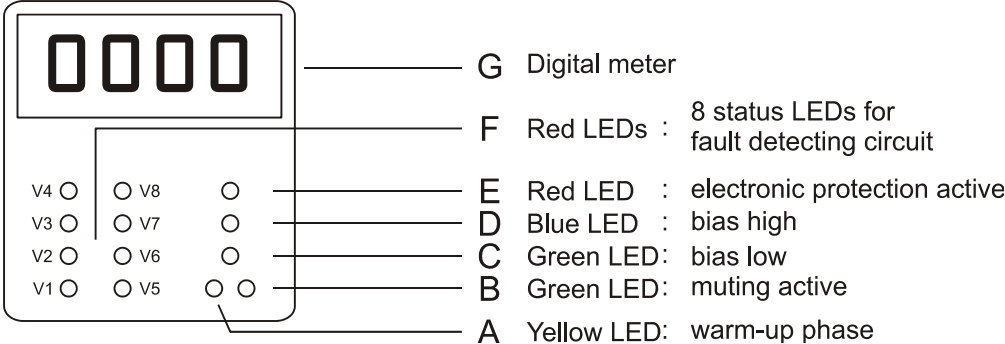
Legend	
①	<p>On/Standby (Power) button</p> <p>The push button switch in the top control panel can only be used to switch the amplifier on when the mains power switch [8] has been turned on at the rear of the unit. 000 will appear in the display [5] to indicate that the unit is On. During the turn-on phase, the yellow LED A (indicating the start phase) and green LED B (indicating that the unit is muted during the start phase) light up in the display (see chap. 5.3).</p>
②	<p>Muting button</p> <p>This function disables the inputs of the power amplifier. The green LED B lights up in the display and the LED next to the input selector switch [10] goes out (see chap. 5.5).</p>
③	<p>Power Pre Selector</p> <p>This function reduces the bias current to approx. 30% of its nominal value. The low bias setting is useful when the power amplifier is to be used at low volume or as a “fast” setting test during the warm up phase for checking the correct operation of the unit and for checking the tube parameters (see chap. 5.4). Overall power consumption is also reduced in this setting, which produces less heat. The green LED C on the display indicates the low bias setting; the blue LED D indicates the high bias setting.</p>
④	<p>Bias measurement selector switch</p> <p>This selector switch simplifies checking and adjusting the idle current of the eight output tubes. The readings are displayed in the digital meter (see chap. 5.1).</p>
⑤	<p>Display</p>  <p style="margin-left: 400px;">G Digital meter</p> <p style="margin-left: 400px;">F Red LEDs : 8 status LEDs for fault detecting circuit</p> <p style="margin-left: 400px;">E Red LED : electronic protection active</p> <p style="margin-left: 400px;">D Blue LED : bias high</p> <p style="margin-left: 400px;">C Green LED: bias low</p> <p style="margin-left: 400px;">B Green LED: muting active</p> <p style="margin-left: 400px;">A Yellow LED: warm-up phase</p>

4. OPERATING COMPONENTS

4.2. Jubilee Mono Ultimate rear panel

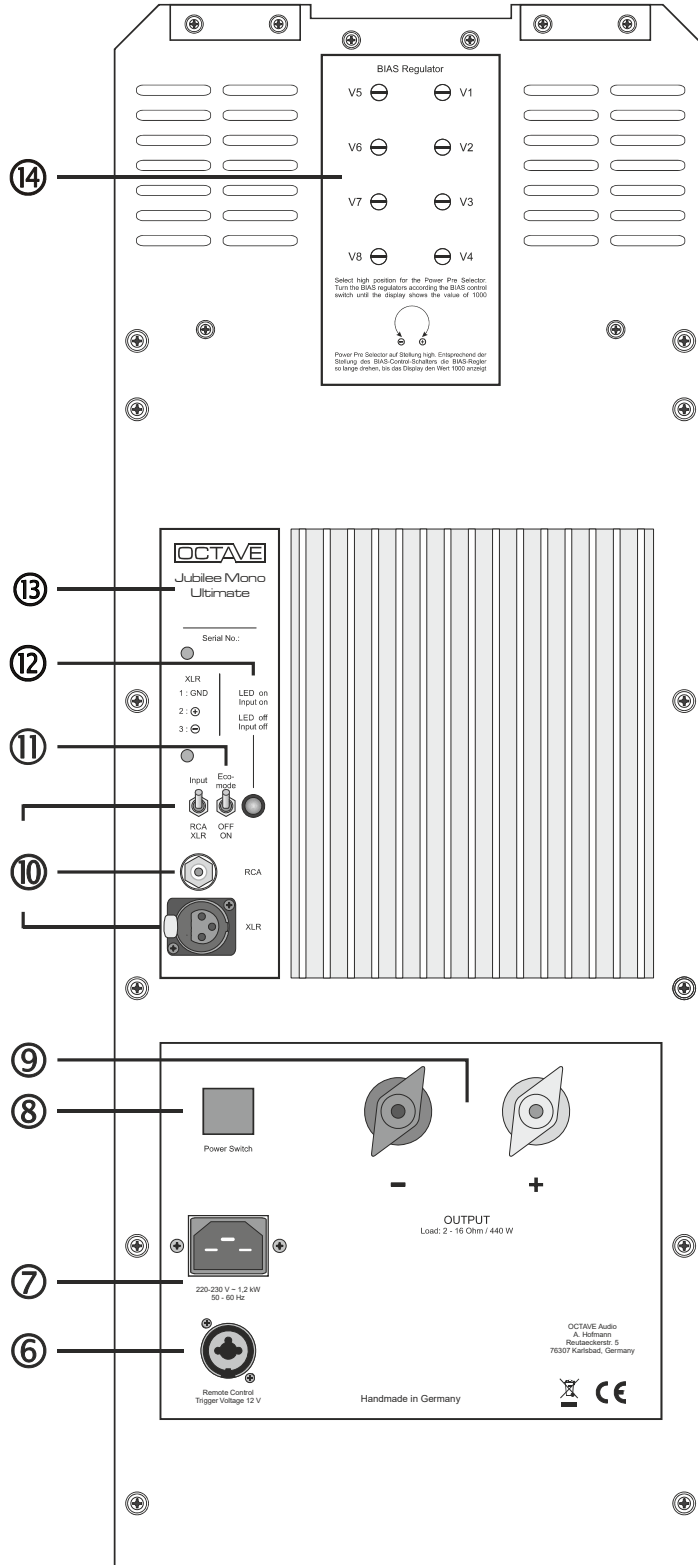

4. OPERATING COMPONENTS

4.2. Jubilee Mono Ultimate rear panel

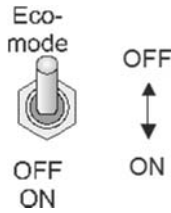
Legend	
⑥	<p>Remote operation DC-Input for remote operation. Connector: 6,3 mm Mono-Plug Voltage: 12 V / 50 mA (see chap. 5.7)</p>
⑦	<p>Mains Input AC input, Type C 19 (20 A) high current socket</p>
⑧	<p>Mains power switch Please make sure that the power switch and the mains input are always accessible</p>
⑨	<p>Loudspeaker outputs Loudspeaker terminals</p>
⑩	<p>Input section The amplifier is equipped with an RCA and an XLR input. You can select the appropriate input using the input toggle switch. You can connect both inputs at the same time and switch between them. XLR pin connections: 1 = ground, 2 = +, 3 = -</p>
⑪	<p>Ecomode Switch</p> <div style="text-align: center;">  </div> <p>Ecomode off: Ecomode automatic is off. Ecomode on: Ecomode automatic is on. (see chap. 5.6)</p>
⑫	<p>Muting LED</p> <ul style="list-style-type: none"> - lights up when the input is active - goes out when the Muting function is activated (see chap. 5.5).
⑬	<p>Model identification plate Model and serial number</p>
⑭	<p>BIAS regulators (see chap. 5.1)</p>

5. ADVANCED FUNCTIONS

5.1 Bias measurement facility

Direction of view from the rear

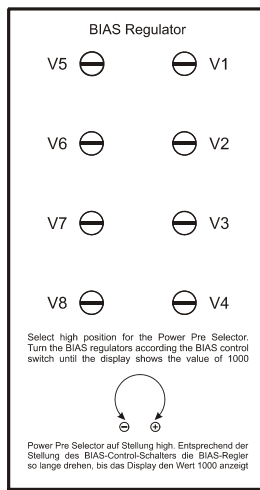
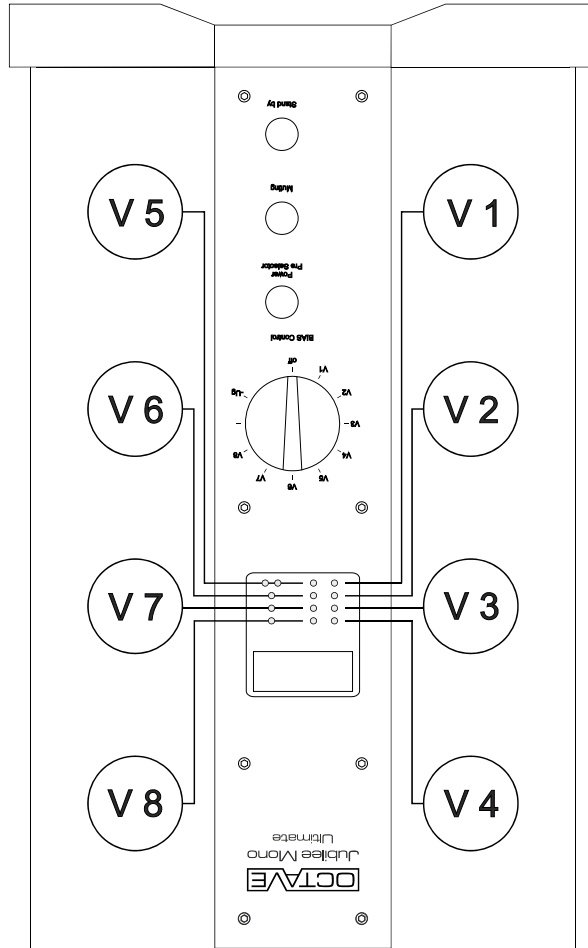

5. ADVANCED FUNCTIONS

5.1. Bias measurement facility

5.1.1. How the bias works

The bias measurement facility makes it easy for you to check and adjust the idle current of the output tubes. Getting the bias setting right for all eight tubes is relevant to both for the sound of the power amplifier and for the service life of the tubes. This is why we have incorporated a bias measurement facility into the Jubilee Mono Ultimate mono blocs that allows you to set the bias yourself without the need for test equipment. The protective cover does not have to be removed to do this.

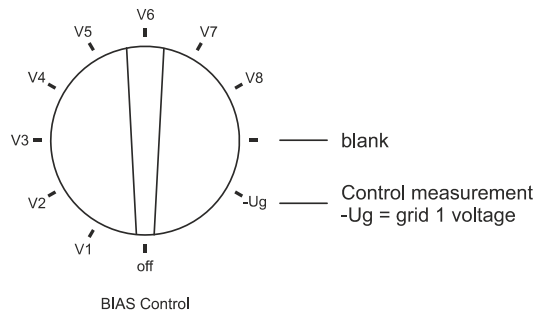

5.1.2. How to set the bias



Make sure that no signal is playing through the amplifier when you are adjusting the bias. The preamplifier should be switched off or the volume should be set to 0, although you do not need to disconnect the loudspeakers.

Procedure

- 1 Power Pre Selector must be in position "BIAS HIGH"
The amplifier must be operated for at least 25 minutes to allow the tubes to reach their operating temperature.
The adjustment is made in the "bias high" setting (blue LED in the display).
- 2 Turn the bias measurement selector switch [4] to position V 1. The meter in the display should read 500 (factory setting). In case of misadjustment you have to adjust the value. The corresponding bias-regulators for the output tubes are located on the rear panel. Turn regulator 1 clockwise in case the reading of tube 1 is less than 500 and counter-clockwise in case the reading is higher than 500. Check the bias of the other tubes, V2 - V8, and adjust their bias via the corresponding regulators
- 3 After adjusting all tubes you should check V 1 up to V 8 again. A small re-adjustment may be necessary to reach the final matching reading of all eight tubes. The reading of all tubes should be equal within the tolerance range from 470 to 530.



To match the power amplifier to the loudspeaker, values of 500, then 750 and 1000 are practicable for all power tubes.

- 4 **Power Pre Selector in position "BIAS LOW"**

Bias LOW is for background music and to break in new tubes. BIAS LOW saves energy and produces less heat. Set the Power Pre selector to bias "Low", indicated by LED C of the display.

Bias low reading: approx. 30% of the "Bias High" value

Turn the knob to check all eight tubes. All eight tubes will give a similar reading. It does not matter, if the reading of the tubes is very different within the range 200 -250.

The BIAS reading value in the setting BIAS Low is depending on the setting of the adjustments in Position BIAS High and cannot adjusted separately. If you make a correction in BIAS Low, you will forcibly misadjust the setting of the High position.

5. ADVANCED FUNCTIONS

5.2. Electronic Protection System

The Jubilee Mono Ultimate features a comprehensive electronic monitoring and protection system. This system will automatically switch off the Jubilee Mono Ultimate in case of a fault occurring in the power section.

The protection system has been designed to keep the unit safe from the consequences of overloads of any kind and to protect the output tubes from current surges.

The RED "Protection" LED E lights up to indicate that the protection system has tripped. Depending on the fault one or more of the eight LEDs in section F (see chap. 4.1) of the display MAY light up additional with the protection LED E. The LEDs in F indicate the tube that was causing the protection to trigger.



The amplifier will not play music once the protection system has tripped and you will not be able to check or adjust the bias setting.

The digital meter will show "000" for each of the eight output tubes once the protection was triggered.

The following conditions can cause the protection system to trip:

- Overdriving the amplifier to excessive levels or with excessive levels of low frequency.
- A speaker cable short circuit while the speakers are being driven at high listening levels.
- A fault in one or more of the output tubes.
- A fault in one of the preamp tubes. This is a very rare situation.

As soon as the protection system has been triggered, the Tube Output stage of the Ultimate remains permanently OFF. You can only deactivate the Protection mode by switching the amplifier off and on again - assuming, of course, that you have fixed the problem. Allow the unit two minutes to cool down before switching it back on. If possible, identify and eliminate the cause of the problem if it was not simply a level that was too high (see chapter 7 "Troubleshooting").

If it is not clear what has caused the protection system to trip, we recommend that you check the bias before attempting to use the amplifier again. Tube faults can result in widely drifting bias settings. When these settings exceed a particular value they can cause the protection system to trip.

Mechanical failures, particularly loose connections, can cause an increase in tube quiescent current. This increase can occur very quickly and is sometimes accompanied by sparking in the tubes. The amplifier goes into protection and the user can no longer locate the tube that caused the problem. For this reason we have built an error detection circuit into the amplifier. In addition to the electronic protection system, this subsystem also monitors the output tubes. However, the fault detection circuit detects which tube is responsible for tripping the protection system and shows this information via the 8 status LEDs F on the display. Each LED is associated with a single output tube. The LED of the defective tube continues to light even if the electronic protection has switched off the amplifier.

Unfortunately this tube detector electronic cannot indicate every tube failure.

5.3. Soft-Start, inrush current limitation

The amplifiers input and output tube heaters as well as its high-voltage rails are logic controlled to ensure that the conduction of the output tubes as well as input stage voltages are constantly monitored and controlled by the **Power Management System** to protect the vital internal parts (tubes, rectifier, electrolytic caps, switches, etc.) against excessive turn-on current.

This increases the lifetime not only of the tubes, but also the caps, while all power related components derive benefit through this system. The Soft-Start is always activated within the start phase after the unit is switched on.



During the Soft-Start-phase, adjusting the bias and listening music is not possible.

5. ADVANCED FUNCTIONS

5.4. Power Pre Selector

The Power Pre Selector allows to set the bias (quiescent current of the tubes) in two settings. “**High**”, indicated by the blue LED D and “**Low**”, indicated by the green LED C.

In position “**High**” the output power is set to maximum and in position “**Low**” the output power and the sound quality is limited. The power consumption of the Jubilee Mono Ultimate amplifier is reduced in the position “**Low**”. “**Low**” is the recommended setting to break in new output tubes and for the case the amplifiers have to deliver low output levels while listening news or something similar.

During the position “**Low**” the reading of the display while checking the bias of the eight tubes is showing a value of 250-400. The deviation of the reading in position “**Low**” is normal and there is no need to adjust the tubes. The reading in position BIAS Low is also depending on the type of the power tubes.

5.5. Muting function

LED B indicates the Muting function in the display. The Muting function is a helpful feature that allows you to connect or disconnect signal cables to the Jubilee Mono Ultimate power amplifiers without switching off the unit.

While “Muting” is active the bias of the tubes is regulated to 0. Therefore it takes a few seconds until the amplifier is playing again after switching off the Muting. Once the input is released the LED near the input jacks lights up.

5.6. Remote operation

The remote control input allows remote operation of the Jubilee Mono Ultimate amplifiers driven by a control voltage of a preamplifier. The remote control input is a 6.3mm mono plug. Such a cable is available from us or the PA accessories market. Normally used for microphones.

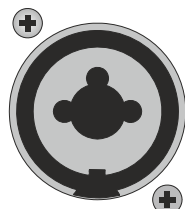

Remote Control

The remote input is not connected to any other voltage inside the Jubilee Mono Ultimate power amplifier. Control voltage and current for the Jubilee Mono Ultimate is 12V, 50mA.

The Jubilee preamp is equipped with two remote switch output jacks on the rear front of the power supply of the preamp.

5. ADVANCED FUNCTIONS

5.7. Ecomode (power saving mode)

The **Ecomode** serves to reduce heat and unnecessary power consumption when the unit is switched on but not in use. After approximately 8 - 10 minutes without receiving signal the Ecomode is turning down the power of the Tube Output stage. In this "sleep" mode, the Jubilee Mono Ultimate draws less than 80 W power compared to approx. 400 W in normal operation mode (in case of BIAS High). Therefore the running unit produces no heat, because the heater voltage and the high voltage of the power amplifier section are switched off. When the music signal is sensed once again by the Ecomode electronic, the Ecomode circuit will turn the unit back on, with a warm-up/start-up delay of approximately 60 seconds until the unit will be operational.

The Ecomode also serves to increase the lifetime of the tubes, while having an added benefit of **improved safety** allowing the Jubilee Mono Ultimate owner a level of security against any problems when leaving the unit powered on. The Ecomode is a safety and energy-saving feature that is unique in our amplifier range.

Eco off: The Ecomode electronic is off. The Jubilee Mono Ultimate is permanent in operation.

Eco on: The Ecomode electronic is activated. After a period of approximately 8 - 10 min without receiving a signal from the preamp the Ecomode electronic is turning the Jubilee Mono Ultimate down. This is indicated through the LEDs A + B.

Note:

If you switch on the Jubilee Mono Ultimate with Ecomode active, it will go through the start procedure. If it fails to detect a music signal, it will shut down after approximately 8 - 10 minutes. Ecomode is not the same as standby, however, because certain sections of the amplifier remain on.



Important!

You cannot adjust the bias in Ecomode once the amplifier has powered down! The signal switching level of 0.5mV results in approx. 40 μ W output power of the Jubilee Mono Ultimate. In case of a speaker with a high efficiency an adjusted listening level can be lower than this value. The Ecomode would drive the unit down. In such cases the Ecomode should be switched off.

6. TUBES

6.1. Tube layout

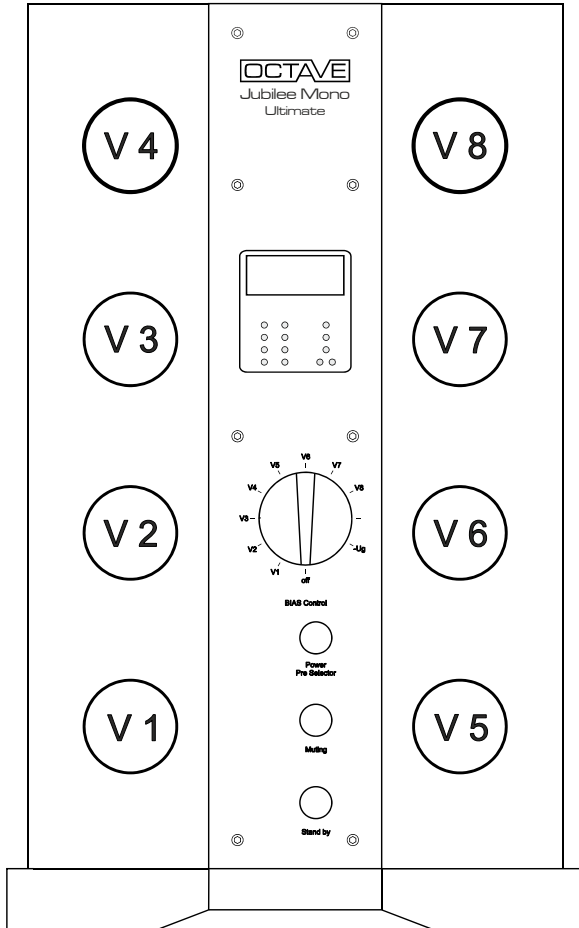

Output tubes:

See chap 3.4. "Installing the power tubes"

V1 - V8: KT170

The output tubes should be selected, but due to the separate bias regulators the selection grade is not critical

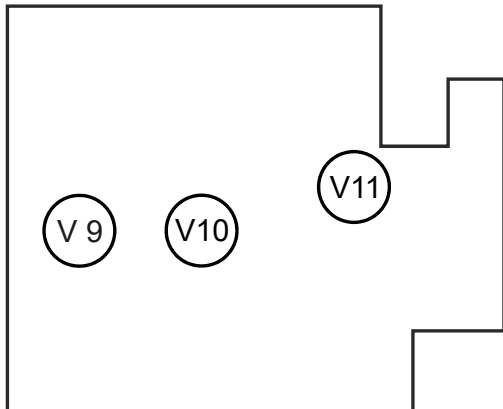

Driver tubes:

V9: ECC99
 V10 + V11: ECC82 (=12 AU 7)

V 9: Output stage driver
 V10: Main amplifier tube
 V11: Input tube



The board is located on the rear panel inside the amplifier. (see chap. 6.4.2)

6. TUBES

6.2. Replacing the power tubes

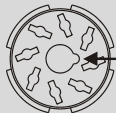

Only qualified personnel should replace tubes.

General Procedure	
1	Switch the amplifier off and disconnect the plug from the mains supply. Allow it to cool down for 10 minutes.
2	Remove the protective grille. (see chap. 6.4.1)
3	Remove the old tubes by carefully pulling out them upwards
4	Fit the new ones. Insert the power tubes into their sockets as shown on the tube layout. Ensure that you correctly locate the anti-rotation lug on each of the tubes
	 Anti-rotation recess on the tube socket
5	 When you have successfully replaced the necessary tubes, don't forget to remove the protective cover again
6	Before you switch the amplifier back on after fitting new output tubes, turn all bias adjustment control regulators counter-clockwise toward minus as far as it will go. The control is a ten-turn potentiometer, i.e. it takes ten revolutions to go from the maximum to the minimum setting
7	Switch the amplifier on, carry out the checks described in chap. 3 and adjust the bias after a warm up time of at least 20 minutes
8	Your amplifier is now ready for use. Depending on the type, age and manufacturer of the tubes, you may need to readjust the settings in the first few weeks.

6.3. Tube service life

- Thanks to the protection circuits and soft start electronics, the output tubes used in your amplifier should achieve an average service life of 3 to 5 years. We cannot, however, guarantee the service life of the tubes. These are average values, which will vary with the type and manufacturer of the tubes.

The internal protection and soft start circuits cannot prevent tube faults. They are designed to minimize the stress on the amplifier and to protect it should a fault develop. You can select tubes by measuring their characteristics but this does not guarantee that they will last for a long time. Indeed, it is impossible to predict how long the output tubes will last.

A well-made tube has a life expectancy of between 3 and 5 years. However, it remains impossible to detect certain weaknesses in the structure of a fully functional tube. The protection circuits in the power amplifier will also protect the unit against the damage that a defective output tube could cause.

- Driver tubes can last for 10 years or longer.
- Because tubes have different service lives, you will never have to renew the entire tube complement at the same time.
- Please note that some tubes need a long time (up to 300 hours) to achieve their optimum sound quality.

6. TUBES

6.4. Replacing the driver tubes

Driver tubes normally do not require periodical replacement.



Operating the amplifier without the side panel is dangerous and not recommended! Tubes should only be replaced by qualified personnel. There are a number of points inside the amplifier that can cause a fatal electric shock if touched.

Procedure	
1	Switch off the amplifier and disconnect the power cord. Wait 20 minutes until the amplifier and the tubes have cooled down
2	Remove the right side panel (viewed from the front)
3	To prevent the side panel from slipping and damaging the screws, support the panel at both front and rear (using paperback books for example)
4	Use the Allen key 2,0 supplied to remove the 13 screws from the side panel. Work from the top down and remove screw S last
5	Remove the side panel
6	Replace the tubes as required in accordance with the tube layout. V11 is the tube closest to the right side panel
7	Replacement driver tubes require no adjustment

Step 1

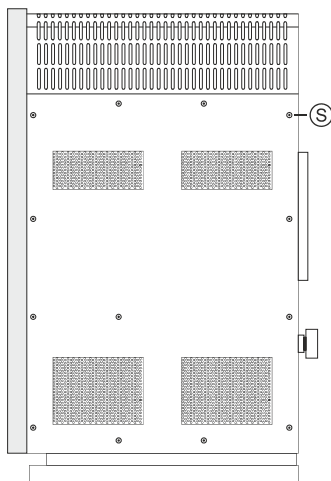

Step 2

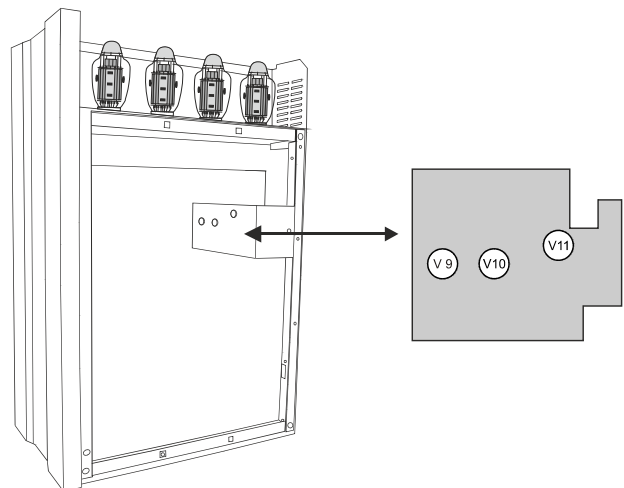

7. TROUBLESHOOTING

7.1. General troubleshooting tips

■ Noise and hum

Hum in an audio system is often caused by several system components being grounded separately. It is particularly common in systems containing tuners, VCRs or satellite receivers connected to an aerial, where a hum loop may be introduced via the aerial input. Although the Jubilee Mono Ultimate is also grounded, it is equipped with a special technology that reliably prevents ground loops. Should an earth loop nevertheless develop via a tuner or television aerial, we strongly recommend that you use a signal-isolating filter on the aerial connection. This will eliminate all ground loops.

Hum when connecting the power amplifier via XLR:

When connecting the power amplifier to a preamplifier using XLR cables, make sure that all three pins are connected at both ends.

■ Switching interference

With older refrigerators, 12 V halogen lamps and drills, etc., there may be clicking noises in the speakers when switching on and off.

Solution:

The only solution is to run your system from a single distribution board - if possible, one that incorporates a mains filter.

■ The channels are unbalanced and/or there is distortion at certain frequencies

The problem of channel imbalance or distortion in one channel is unlikely to be caused by defective tubes. The most frequent causes are cables and poor contacts of a signal cable connector.

Solution:

Unplug all non-essential components/cables from your preamp. Swap channels to check your speaker and interconnect cables. You will generally be able to locate the fault if it changes channel or disappears altogether.

7. TROUBLESHOOTING

7.2. Identifying defective tubes

There are especially five reasons why tubes can become defective.

You should remove any tube that fails to provide a stable reading after an initial warm up period.

Any tube that reads 0 is defective and non-functional and must be replaced. Tubes showing a reading of 0 cannot be corrected by turning up the bias control. This can be in case of a damaged heater of this tube – this tube is not glowing.

If you notice a constantly rising reading on a tube, accompanied by the red protection LED E turning on at some point, this means that the power amplifier has switched itself off electronically. The readings for tubes V 1 - V 8 then fall to 0. No adjustment is possible if the electronic protection is triggered. (See chap. 5.2 “Electronic protection”)

1. Breakage of the heater filament and internal contact problems

The tubes operating current normally drops to 0 when this fault occurs. Because of this, the electronic protection does not cut in. You can confirm this type of fault using the bias measurement facility while the amplifier is on. The problem tube will give a very low reading, or a reading of 0. Use the rotary selector switch to determine the location of the faulty tube. Then replace it (see chap. 6.2 Replacing tubes).

2. Leaking glass envelope

In order to function properly, there must be a vacuum inside a tube. Tiny hairline cracks or defects in the glass casing can allow small amounts of air to enter the tube. When air enters for the first time, the effect is not initially noticeable. However, the bias measurement system allows you to track such tubes as they produce a highly fluctuating reading. As more air enters the tube, the shiny silver surfaces in the glass casing turn white. The readings for these tubes are around 0. As soon as air gets into the tube, the filament burns out. Such a tube failure will not cause damage to other parts of the amplifier. You should replace any tubes suffering from this problem (see chap. 6.2 Replacing tubes).

3. Signs of tube aging

It will normally be necessary to re-bias output tubes at some time during their service life to bring the idle current back to the prescribed setting. Depending on the age, quality, type of construction and the materials used inside the tube, the bias setting may be quite different after a number of years from that of a brand new tube.

You can re adjust the BIAS according chapter 5.1.

4. Uncontrolled rise in tube idle current

Mechanical failures, particularly loose connections, can cause an increase in tube quiescent current. This increase can occur very quickly and is sometimes accompanied by sparking in the tubes. The amplifier shuts down and the user can no longer locate the tube that caused the problem. For this reason we have built an error detection circuit into the amplifier. In addition to the electronic protection system, this subsystem also monitors the output tubes. However, the fault detection circuit detects which tube is responsible for tripping the protection system and shows this information via the 8 status LEDs F on the display. Each LED is associated with a single output tube. The LED of the defective tube continues to light even if the electronic protection has switched off the amplifier off.

You should replace this problem tube (see chap. 6.2 Replacing tubes).

8. TECHNICAL DATA AND DIMENSIONS

Mono Power Amplifier Jubilee Mono Ultimate	
Output Power into 4 ohms	440W RMS 500W peak power into 4 ohms
Power Bandwidth	10Hz - 80kHz / ± 0.5 dB
Signal-to-noise ratio	> 106 dB @ 400W
Gain/input sensitivity	+ 27.5 dB / 1.7V
Input Resistance	50 k Ω RCA; 25 k Ω XLR
Minimum load impedance	3 ohms
Total harmonic distortion	< 0.1% at 10W into 4 ohms
In- and Outputs	
Inputs	1 x RCA, 1 x XLR
Outputs	1 x Loudspeaker output
General Data	
Power consumption	420W idle, 1200W @ full power Eco on: < 80 W
Mains voltage	100 V / 115-120 V / 220-230 V / 240 V available
Mains Input	C19 High Current Connector
Weight	78,3 kg per monobloc
Dimensions	Overall dimensions in mm: 280 mm x 740 mm x 490 mm (W x H x D)

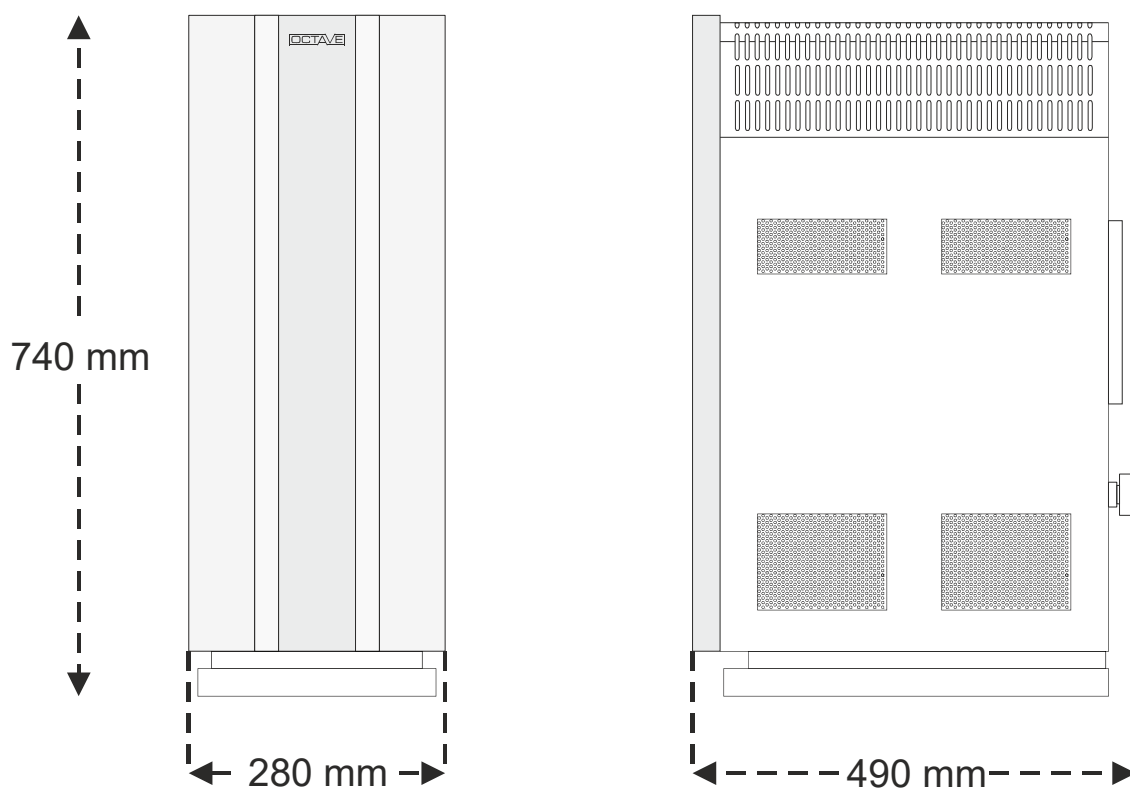

9. TECHNICAL DATA, DIAGRAMS

Distortion in % at 10W into 4 ohms between 30 Hz and 20 kHz
at a variety of bias settings

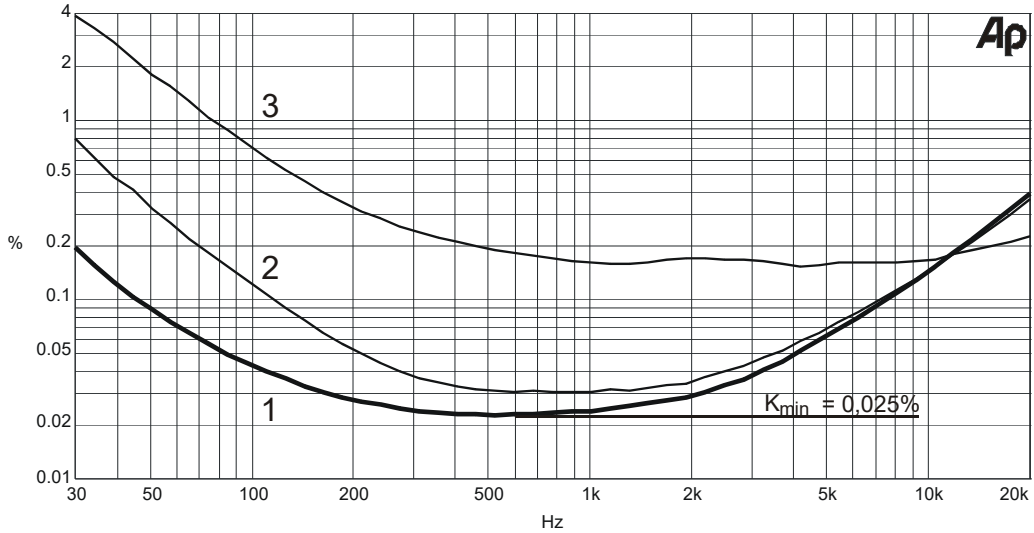

- Curve 1: Bias adjusted correctly; bias high with selected tubes
- Curve 2: Distortion curve with unselected tubes
- Curve 3: Distortion curve bias low

Frequency response

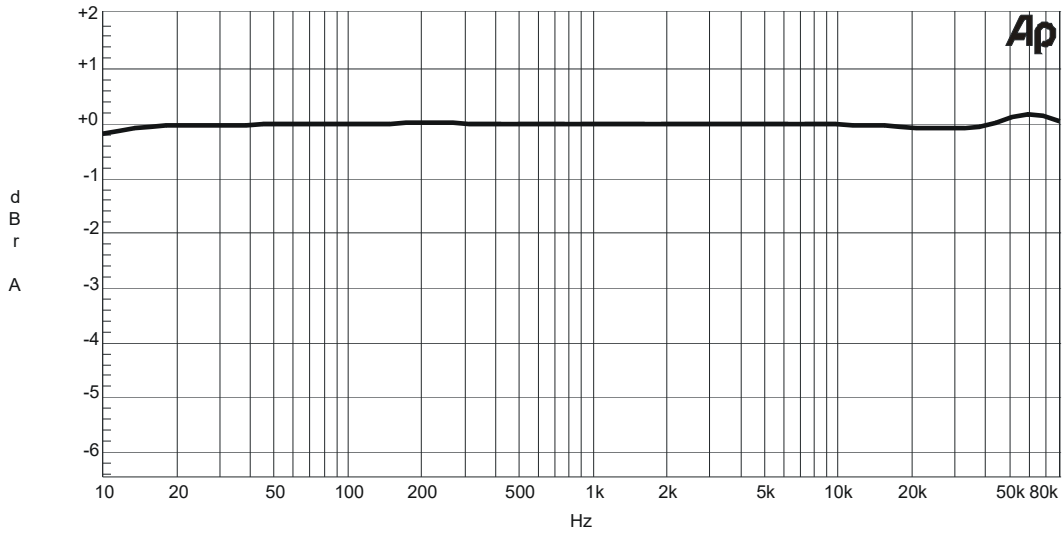

Between 10 Hz and 90 kHz the frequency response tolerance is within 0.3dB ±

9. TECHNICAL DATA, DIAGRAMS

Noise spectrum (1 kHz at 10V)

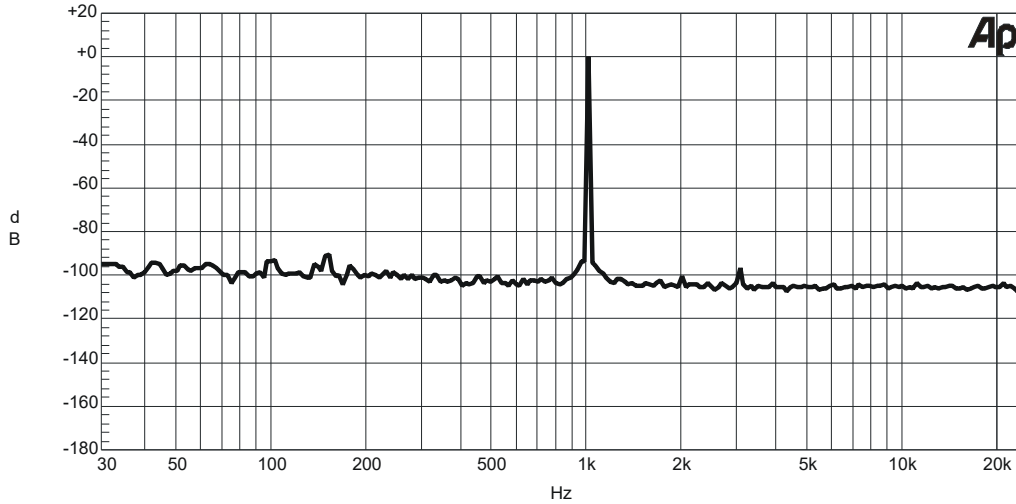

The FFT analysis demonstrates the superb spectral purity of the output signal. No mains-borne noise (normally at 50 and 100Hz) is present

THD between 30Hz and 20 kHz

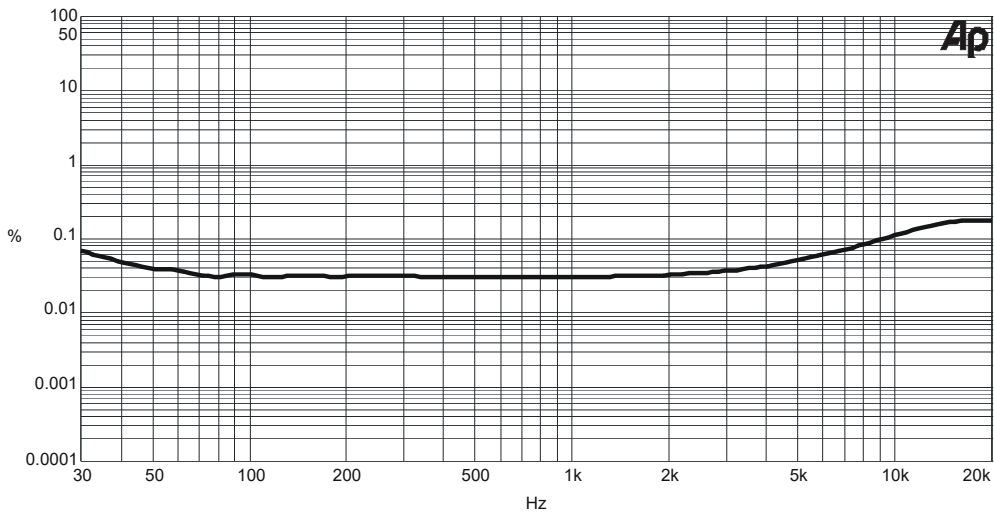

The total harmonic distortion curve is very linear, increasing only slightly at the lowest frequencies. This performance is only possible using a highly specialist output transformer.

10. FAQ

1. Can you operate the amplifier when no loudspeakers are connected?

Yes. All OCTAVE amplifiers are protected against open circuit conditions, i.e. they will not be damaged if operated with the loudspeakers disconnected. However, when connecting your loudspeakers to the amplifier, you should set the volume control on your preamp to 0 to avoid excessive output to the speakers. Protected against open circuit conditions here means without any speakers or speaker cable connected. If you use a "high capacitance" speaker cable, you should make sure that you connect the cable first to the speakers and then to the amplifier.

2. Can a short circuit on the speaker outputs damage the amplifier?

At low levels, the power amplifier is absolutely short-circuit proof. At higher levels, the electronic protection is activated. Under normal circumstances, a short circuit condition at the speaker outputs will not damage the amplifier.

3. How do you recognize a faulty tube?

There are 3 different symptoms indicating a faulty tube:

1. Broken heater filament: the tube stops glowing.
2. Defective cathode layer: the tube glows, but no current can flow. This fault will be shown on the bias display.
3. Short circuit within the tube: This fault will normally trip the electronic protection and cause the red OFF LED to illuminate.

With faults 1 and 2, the amplifier will still operate, although the channel containing the faulty tube will be quieter than normal. At low listening levels, the fault may not be obvious, but distortion will become evident at higher listening levels.

If fault 3 occurs, the protection circuits will normally switch the amplifier off. You may also hear loud background noises just before it switches off, although these will not harm the amplifier. (See chap. 7.2.)

4. Is there a loss of sound quality as tubes age?

No. Tubes normally sound the same throughout their service life.

Our soft-start technology contributes greatly to extending the service life of tubes. You can see when an output tube has reached the end of its useful life: it becomes impossible to adjust its bias correct. Driver tubes cannot be checked, but these will generally last for well over 10 years.

5. Does the power amplifier have to have all power tubes fitted?

No. The power amplifiers have been designed to operate without a full complement of output tubes for test purposes, or as an interim measure. Power output will, of course, be reduced. Normally, operating the amplifier like this for extended periods will not result in any damage. However, you must not try to run the amplifier at full power.

6. What is the significance of loudspeaker impedance and efficiency?

The impedance and efficiency of modern loudspeakers is not an issue for OCTAVE amplifiers. The often-quoted damping factor is not normally a guarantee that an amplifier will exert tight control over the loudspeakers. In practice, speakers of 85dB efficiency and above are suitable for use with tube amplifiers. The high stability of the OCTAVE power amplifier technology even allows the use of speakers whose impedance dips as low as 2 ohms.

7. What cables are suitable for tube power amplifiers?

The cable manufacturers are now offering cables that have supposedly been designed specifically for tube amplifiers. Although such cables may be of good quality, there is no need to use special cables with tube amplifiers. Speaker cable can exhibit high values of capacitance and inductance. Tube power amplifiers deal with such loads better than transistor power amplifiers. The only exception would be in the case of tube preamp to power amp interconnect cable longer than 5 meters. In this instance, a low capacitance cable is advisable.

07/26



We reserve the right to alter and improve the specifications in pursuit of better. OCTAVE logo is a registered trade mark of Andreas Hofmann. Copyright by Andreas Hofmann

OCTAVEAUDIO T. +49 (0) 7248 3278
ANDREAS HOFMANN F. +49 (0) 7248 3279
REUTAECCKERSTR. 5 INFO@OCTAVE.DE
DE-76307 KARLSBAD WWW.OCTAVE.DE